

**WINGET**

**OPERATING  
INSTRUCTIONS  
&  
SPARE PARTS  
LIST**

**FOUR/30  
DIESEL  
DUMPER  
(CAPACITY 30 CWT)**

**ISSUED SEPTEMBER 1976,  
MARCH 1980**

**REPRINTED JULY 2002**

**WINGET LIMITED  
PO BOX 41  
EDGEFOLD INDUSTRIAL ESTATE  
PLODDER LANE  
BOLTON  
LANCS  
BL4 OLS**

**TEL: ++ 44 (0) 1204 854650**

**FAX: ++ 44 (0) 1204 854663**

**service@winget.co.uk**

**parts@winget.co.uk**

**www.winget.co.uk**

## **INTRODUCTION**

This Parts & Operators Manual is a re-print of the manual last published in 1980 and contains some amended part numbers.

Health & Safety legislation and working practices applicable to Site Dumpers, both 2 and 4 wheel Drive, Rigid Chassis and Articulated Chassis have changed considerably in the years since this manual was last published and immediately following this Introduction are notes on the Safe Use of Site Dumpers. These notes supersede and replace all previous 'Dumper Safety' notes issued with Winget FOUR/30 Four Wheel Drive Dumpers

Reference is made on a number of pages to 'bolt c/w nut and washer', this no longer the case, fixings such as nuts, bolts, screws and washers should be ordered as individual items. A number of Whitworth and B.S.F fixings are now no longer available, in these cases the nearest metric equivalent size will be supplied.

The contents of this manual although correct at the time of publication, may be subject to alteration by the manufacturers without notice and Winget Limited can accept no responsibility for any errors or omissions contained within the following pages. Nor can we accept any liability whatsoever arising from the use of this manual howsoever caused.

Winget Limited operate a policy of continuous product development. Therefore, some illustrations or text within this publication may differ from your machine.

**WINGET LIMITED**  
**PO BOX 41**  
**EDGEFOLD INDUSTRIAL ESTATE**  
**PLODDER LANE**  
**BOLTON**  
**LANCS**  
**BL4 OLS**  
**TEL ++ 44 (0) 1204 854650**  
**FAX ++ 44 (0) 1204 854663**  
**E mail [service@winget.co.uk](mailto:service@winget.co.uk)**  
**[parts@winget.co.uk](mailto:parts@winget.co.uk)**  
**[www.winget.co.uk](http://www.winget.co.uk)**

# DUMPER SAFETY

---

**Safety is the responsibility of all persons working with this machine. Think "safety" at all times. Read and remember the contents of this handbook.**

## MACHINE MODIFICATIONS

**WARNING** Any modifications to the machine will affect its working parameters and safety factors. Refer to the Manufacturers before fitting any non-standard equipment or parts.



The Manufacturers accept no responsibility for any modifications made after the machine has left the factory, unless previously agreed by the Manufacturers in writing; the Manufacturers will accept no liability for damage to property, personnel or the machine if failure is brought about due to such modifications, or fitment of spurious parts.

## TRAINING

**WARNING** Only trained operators should use this machine.



Operators should hold an appropriate full motor vehicle driving licence and undergo both a safety awareness course and a driver training course for Site dumpers run by the C.ITB or equivalent body leading to the award of a CTA.

It is strongly recommended that operators read the H.S.E. publication "Safe Working with Small Dumpers" which is available from government bookshops (HMSO) or from other bookshops quoting the following number ISBN 011 8836935. Another useful publication is British Standard number BS 6264, "Procedure for Operator Training For Earth Moving Machinery" available from the British Standard Institution.

## OPERATION

**WARNING** NEVER use the machine for purposes other than those for which it was designed. This machine was designed to carry loads such as soil, clay, sand, wet concrete, stone or other similar materials. It was not designed to carry loads which may move around in the skip uncontrollably, nor to carry any loads or materials which overhang the skip in any way. If in any doubt as to the suitability of this machine for a particular task, contact your nearest Distributor or the Manufacturer for advice.



ALWAYS be aware of local and national regulations governing the use of the machine.

NEVER commence work with the machine until the "Daily (or every ten hours)" service checks have been made. (See Service Section for details)

ALWAYS check wheel nut tightness daily.

NEVER carry passengers.

Where seat belt restraints are fitted as part of Rops/Fops Protection they must be worn. Ensure that the seat and seat belt are securely fixed to the machine. Check that the seat belt is in good condition, free from cuts and frayed edges.

ALWAYS remain in the driving seat whenever the engine is running. Never attempt to operate any controls unless seated.

ALWAYS apply the parking brake before leaving the driver's seat.

## DUMPER SAFETY

---

*NEVER* dismount with the engine running, and never leave the machine unattended with the key in the starter switch.

When Battery Isolators are fitted they must be activated only when the engine is turned off except in cases of emergency.

Activating a Battery Isolator when the engine is running can result in damage to the electrical components and circuits.

*NEVER* fill the fuel or hydraulic tanks with the engine running.

*ALWAYS* drive only on surfaces that are known to be stable.

*ALWAYS* keep the floor plates and walkways clean.

*NEVER* drive the machine close to the edge of any excavation. Always use effective wheel stops to prevent the machine running close to the edge. Make sure that the stops are in proportion to the size of the wheels and are set sufficiently far enough back from the edge of any excavation to prevent the weight of the load causing a collapse.

*NEVER* adjust the tyre pressures in an attempt to improve traction on soft ground or obtain a softer ride on hard ground. Incorrectly adjusted tyres can affect the steering and handling characteristics.

*NEVER* attempt to free a machine which is 'bogged down' by pushing with the bucket of a backhoe loader, tracked excavator or other similar machine.

*NEVER* make unnecessary "crash stops" when travelling at speed, especially in forward direction.

*NEVER* work under an unpropped skip. *If the dumper was supplied with a special Skip Support always ensure that it is used.*

*Some articulating dumpers are manufactured with an articulation lock. If your machine has this feature proceed as follows:*

*ALWAYS* fit the articulation lock when working within the articulation point crush zone.

*NEVER* attempt to lift the machine unless the articulation lock is engaged.

## SKIPS AND LOADING

**WARNING** *NEVER* exceed the rated payload. The weights of all loads above skip water level must be checked.



*NEVER* remain on the machine when loading the skip with excavators or loaders. Stop the engine, apply the parking brake, dismount, and stand well clear.

*ALWAYS* ensure that the load is evenly distributed in the skip.

*NEVER* carry loads or heap materials in such a manner as to affect the forward vision.

*ALWAYS* take extra care when tipping non free running loads.

*NEVER* use the skip in a tipped position to bulldoze heaped materials level or to backfill material into excavations.

# DUMPER SAFETY

---

## TOWING

**WARNING** NEVER attempt to start the engine of a dumper by towing or pushing.



Dumpers are not designed as towing vehicles, but loads (including weight of trailer) not exceeding the rated payload of the dumper may be towed on dry level ground in first gear, providing the dumper skip is loaded with half the rated payload to ensure tyre adhesion when braking.

ALWAYS use a purpose made towing pin.

NEVER tow loads up, down or across gradients.

## GRADIENTS

**WARNING** NEVER operate *Four Wheel Drive articulated steer dumpers* on any gradients which exceed 25% (1 in 4), or across gradients which exceed 16% (1 in 6).



NEVER operate *Two Wheel Drive rigid chassis dumpers* on any gradients which exceed 10% (1 in 10), or across gradients which exceed 10% (1 in 10).

ALWAYS remember that slippery or loose surface conditions can adversely affect safe machine operation, including braking, particularly on gradients.

ALWAYS choose routes that avoid steep, slippery or loose gradients.

NEVER coast down gradients. Always negotiate gradients in first gear.

ALWAYS drive forwards up gradients when loaded.

ALWAYS reverse down gradients when loaded.

ALWAYS keep the load facing uphill.

NEVER park on a gradient. If this is unavoidable, ALWAYS chock the wheels.

NEVER attempt to turn on a gradient.

NEVER tow up, down or across a gradient.

NEVER operate high discharge or rotating skips on gradients.

## HYDRAULICS

**WARNING** ALWAYS "Dump" residual pressure from the system before leaving the machine or before carrying out any maintenance or adjustments.



If maintenance work requires the skip to be in the raised position, then it must be raised and supported before dumping the pressure.

Dump pressure by switching off the engine, then moving the hydraulic control lever several times in each direction.

NEVER leave the machine unattended with pressure in the system.

ALWAYS purge hydraulic rams before commencing work. With the engine running operate the hydraulic control to fully extend and retract the rams.

ALWAYS practise the greatest cleanliness in maintaining hydraulic components.

# DUMPER SAFETY

---

## SERVICING

**WARNING** ALWAYS report any defect at once, before an accident or consequential damage can occur.



ALWAYS conform to service schedules except where:

- 1 Warning lights or warning indicators call for immediate attention.
- 2 Adverse conditions necessitate more frequent servicing.

ALWAYS wear correctly fitting protective clothing. Loose or baggy clothing can be extremely dangerous when working on running engines or machinery.

ALWAYS, where possible, work on or close to engines or machinery only when they are stopped. If this is not practical, remember to keep tools, test equipment and all parts of your body well away from the moving parts.

ALWAYS dump pressure from the hydraulic system before carrying out any kind of maintenance or adjustment. (*see Hydraulics Warnings*).

ALWAYS avoid contact with exhaust pipes, exhaust manifolds and silencers when the engine is running; these can be very hot.

ALWAYS work out of doors, or in a well-ventilated area.

NEVER run an engine in an enclosed space. Exhaust fumes in enclosed areas can kill.

ALWAYS disconnect battery cables and remove battery before using an external charger, carrying out welding repairs or to prevent unauthorised usage when unattended or during a repair.

NEVER allow unqualified personnel to attempt to repair, remove or replace any part of the machine, or anyone to remove large or heavy components without adequate lifting tackle.

NEVER attempt to modify or repair Rops Frames or Fops Canopies by welding, drilling or any other means. Attempts to do so will invalidate Rops/Fops Certification.

ALWAYS obtain advice before mixing oils; some are incompatible. If in doubt drain and refill.

NEVER allow oils and fuels to come into regular contact with skin. This can lead to serious skin diseases including, medical evidence suggests, skin cancer. ALWAYS wear protective gloves when handling oils and fuels whether topping up, draining or refilling. ALWAYS wash hands if oils or fuels come into contact with the skin.

Many liquids used in this machine are harmful if taken internally or splashed into the eyes. In the event of accidentally swallowing oils, fuels, anti-freeze, battery acid etc, DO NOT encourage vomiting, seek qualified medical assistance immediately.

ALWAYS dispose of waste oils and fuels into waste oil storage tanks. If storage tanks are not available consult your distributor or local authority for addresses of local designated disposal points. It is illegal to dispose of waste oil into drains or water courses or to bury it.

## DUMPER SAFETY

---

Equipment which includes friction materials will sometimes contain asbestos. When removing friction material dust from components, such as when servicing brakes or clutches, do not blow out with an airline; it could be harmful to inhale the dust. Remove the dust with a vacuum cleaner or wipe clean with a damp rag. Waste should be placed in a sealed container, marked, and disposed of in accordance with local or national regulations.

The accumulated dust found in clutch housings may contain lead/antimony. No food should be eaten at a work place contaminated by this dust. Hands must be washed before eating. Do not blow out dust with an airline.

*ALWAYS* ensure that the starting handle is clean and in good condition. Keep the engine starting dog, and the part of the starting handle that mates with it, lightly lubricated (*Refer to the Engine Handbook*).

*NEVER* work under an unpropped skip. *If the dumper was supplied with a special Skip Support always ensure that it is used.*

*Some articulating dumpers are manufactured with an articulation lock. If your machine has this feature, ALWAYS fit the articulation lock when servicing or working on the machine.*

## PREPARATION FOR USE

BEFORE THE FOUR/30DUMPER IS PUT INTO SERVICE ALWAYS CHECK THE FOLLOWING POINTS:—

- 1. Engine**  
Check the oil level on the dipstick, topping up if necessary to the full mark. See 'General Maintenance', pages 6 & 7, also 'Recommended Lubricating Oils'.
- 2. Gearbox**  
Check the oil level on the dipstick, topping up if necessary to the full mark. See 'General Maintenance', pages 6 & 7, also 'Recommended Lubricating Oils'.
- 3. Drive Axles and Transfer Case**  
Remove filler/level plugs from drive axles & filler/level plug from transfer case and check that oil is up to bottom of holes. Top up if necessary, through filler/level plugs. See 'General Maintenance', pages 6 & 7, also Recommended Lubricating Oils'.
- 4. Fuel Tank**  
Fill tank with diesel oil until approximately 1" from the top.  
**NOTE:—** Never allow fuel level to fall below 2" deep in the bottom of the tank.
- 5. Hydraulic Tank**  
Fill the hydraulic tank. Before removing the cap, clean the surrounding area, to prevent the possible entry of foreign matter. See 'General Maintenance', pages 6 & 7, also 'Recommended Lubricating Oils'.
- 6. Brake System**  
Ensure that the brake master cylinder reservoir is full of brake fluid. Top up if necessary to within 1/4" of the top of the reservoir. Use only brake fluid that conforms to SAE J 1703. See 'General Maintenance' pages 6 & 7, also Recommended Lubricating Oils.
- 7. Miscellaneous**  
Check all wheel nuts for tightness.  
Check all nuts and bolts for tightness. Loose nuts and bolts may lead to damage not covered by the Dumper Warranty.

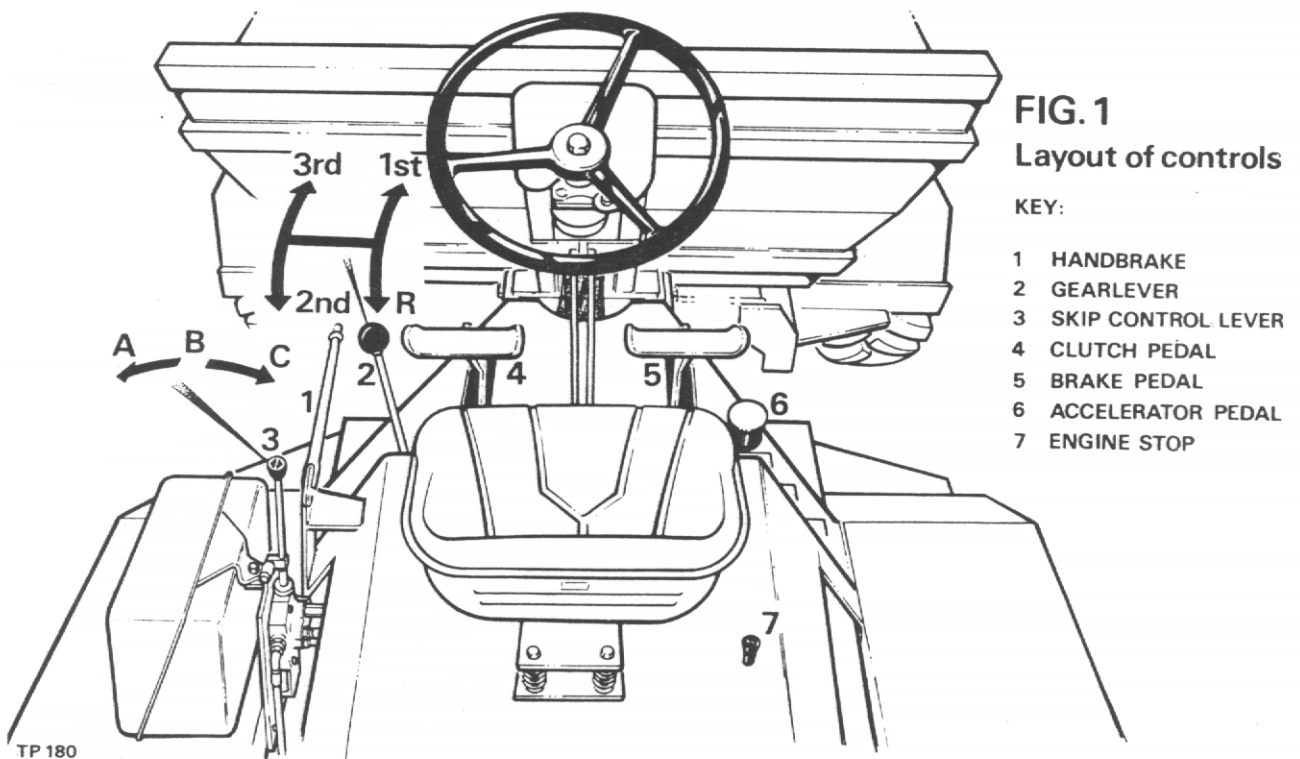



## OPERATION

### Starting

(See Fig.2)

1. Lift red-painted overload stop (A) situated on the fuel pump rack above and to the rear of the priming levers (B) and move fuel pump rack (C) into fully-open position.
2. Operate priming levers (B) six times.

NOTE:— This is unnecessary if engine is already warm.

3. Lift decompression lever (D), positioned on top of engine and turn engine as fast as possible using starting handle. When engine is turning at a good speed, knock down decompression lever and engine should fire.
4. If engine does not fire, lift decompression lever and slowly crank engine a few times before attempting to start again. Where ambient temperature is 5°F (–15°C) or below, a cold start aid should be fitted.

### Stopping

(See Fig.1)

Pull up stop control knob and hold in its fully raised position until engine stops. Release stop control knob when engine has ceased to turn.

### IMPORTANT:

1. DO NOT stop engine by means of decompression levers, this will lead to damaged valve seats and cylinder head joints.
2. DO NOT stop engine by closing fuel tap or by allowing fuel tank to run dry, this will allow air into fuel lines and necessitate bleeding and priming system.

### Gear Shift Lever

(See Fig.1)

The Four/30 Dumper is fitted with three forward (1), (2), (3), and one reverse (R) gear. When changing gear, the clutch pedal is used in the normal manner.

### Skip Control Lever

(See Fig.1)

1. Control lever has three positions DUMP (A), HOLD (B), and RETURN (C).
2. Push lever outward to DUMP (A) to deposit load.
3. Pull lever back to RETURN (C) to return skip carrying position.

NOTE:— If lever is released when in DUMP or RETURN position, it will automatically return to HOLD (B) position and motion of skip will cease. In this way, speed at which load is deposited can be finely controlled.

### Turntable (if fitted)

Pull cranked release lever on turntable catch fully back to release turntable. Revolve skip to required position. To lock in position lift release lock lever and ensure that locking lug locates in turntable locking plate. Cranked release lever will return to its former position.

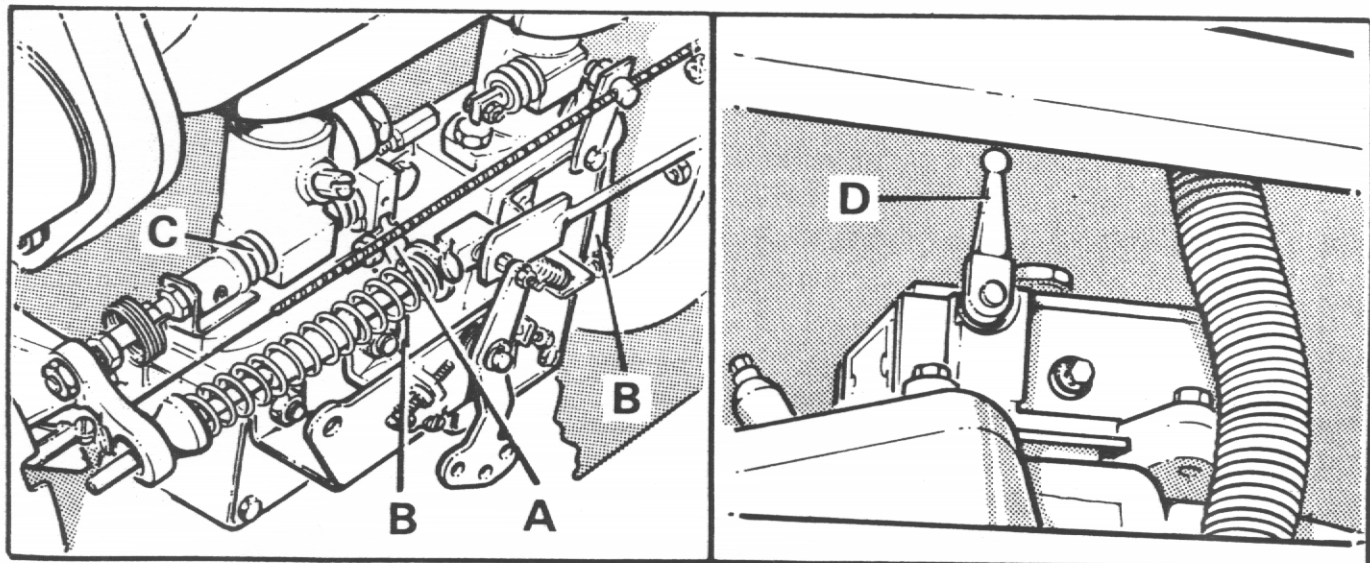

## GENERAL MAINTENANCE

### Periodic Maintenance

1. DAILY check engine oil level and fill to full mark on dipstick, if necessary.
2. DAILY fill fuel tank, or as often as proves necessary to approximately 1" of top. Never allow there to be a depth of less than 2" of fuel in tank.
3. WEEKLY check oil level in gearbox and fill to full mark on dipstick, if necessary.
4. WEEKLY remove filler/level plugs from drive axles and transfer case. Oil level should be to bottom of holes. Top up, if necessary through filler/level plugs.
5. WEEKLY check oil level in hydraulic tank. Always clean the surrounding area before removing cap to prevent possible entry of foreign matter. Fill tank, if necessary, to within 1" of top.
6. WEEKLY check brake fluid level in master cylinder reservoir and top up if necessary, to within ¼" of top.
7. WEEKLY apply grease to all grease nipples.
8. WEEKLY check all wheel nuts and tighten, if necessary.
9. WEEKLY check tyre pressures 32 lb/sq.in.
10. WEEKLY check all nuts and bolts, and tighten if necessary.

### Lubrication (See Fig.3)

Period	Key	Description	Lubrication	No. of Points
Daily	1	Engine	Engine Oil	1
	2	Fuel Tank	Diesel Fuel	1
Weekly	3	Gearbox	Gearbox Oil	1
	4	Drive Axles	Axle Oil	2
	5	Hydraulic Tank	Hydraulic Fluid	1
	6	Brake Master Cylinder Reservoir	Brake Fluid	1
	7	Footbrake Pedal	Grease Gun	1
	8	Footbrake Compensator Lever	Grease Gun	2
	9	Clutch Pedal	Grease Gun	1
	10	Clutch Cross Shaft	Grease Gun	2
	11	Skip pivot	Grease Gun	2
	12	Handbrake Cable	Grease Gun	1
	13	Chassis Centre Pivot	Grease Gun	2
	14	Prop Shafts and Universal Joint	Grease Gun	1
	15	Transfer Case	Axle Oil	1
	16	Drive Axle and Hub Bearings	Grease Gun	4

N.B. FOR RECOMMENDED LUBRICATING OILS SEE CHART ON PAGE 14

### Oil Capacities

Transfer Box . . . . .	1pt. (.57 litres)	Drive Axle . . . . .	8 pts. (4.57 litres)
Gear Box . . . . .	2 pts. (1.14 litres)	Engine . . . . .	12 pts (6.82 litres)

- NOTES: 1. Rear Axle articulation points consist of bearings that require no lubrication.  
 2. For full details of the lubrication and maintenance of the engine refer to Manufacturers Manual.

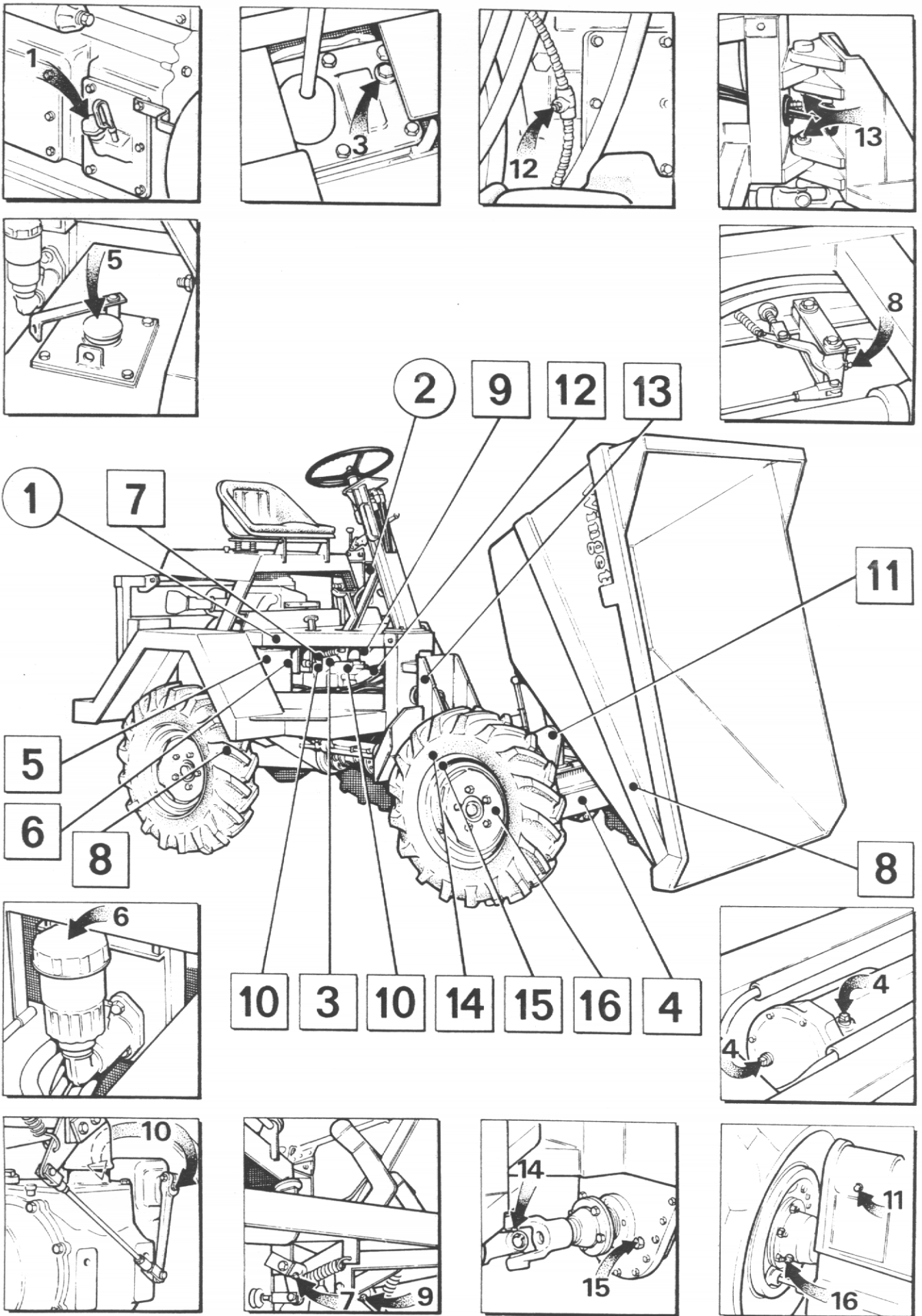

tp 208

FIG. 3

## Brake Adjustment

The brake adjusting screw is located on the rear of the brake back plate (See Fig. 4).

- a) Screw the adjuster (A) clockwise until the brakes are fully on.
- b) Then slacken the screw anti-clockwise until the brake shoes are just clear of the drum. This will cause the shoes to be centralised on the drum and ensure the whole brake lining area is used.

## Brake System

The brake system is designed to require the minimum amount of maintenance, and, providing the hydraulic fluid in the reservoir is not allowed to fall below the recommended level, no defects should normally occur. Fluid loss must be supplemented by topping up the reservoir with brake fluid that conforms to SAE J 1703. No other fluid may be used. If air is present in the system it will be indicated by sluggish response of the brakes and spongy action of the brake pedal. This may be due to air being introduced at a loose joint or by the reservoir fluid level being allowed to fall very low. These defects must be remedied immediately and the complete system bled.

To bleed the system proceed as follows:—

1. Check all connections are tight and the bleed screws on the slave cylinders are closed.
2. Fill reservoir with brake fluid that conforms to SAE J. 1703.
3. Attach bleeder tube (A) (See Fig. 5) to the bleed screw (B) on the front slave cylinder, immerse the other end of the tube in a small quantity of brake fluid contained in a glass jar (C). Slacken bleed screw and operate brake pedal up and down to its full stroke until fluid pumped into the jar contains no air bubbles. Hold pedal down and close bleed screw. Remove bleeder tube and release pedal.
4. Lock the bleed screw and top up the reservoir to the correct level.
5. Repeat the procedure for the rear slave cylinder.
6. Apply normal working load on brake pedal for two or three minutes and examine system for leaks.

**NOTE: DURING THE OPERATION IT IS ESSENTIAL THAT THE RESERVOIR LEVEL IS KEPT TOPPED UP TO PREVENT FURTHER AIR BEING DRAWN INTO THE SYSTEM. ONLY USE NEW FLUID FOR TOPPING UP.**

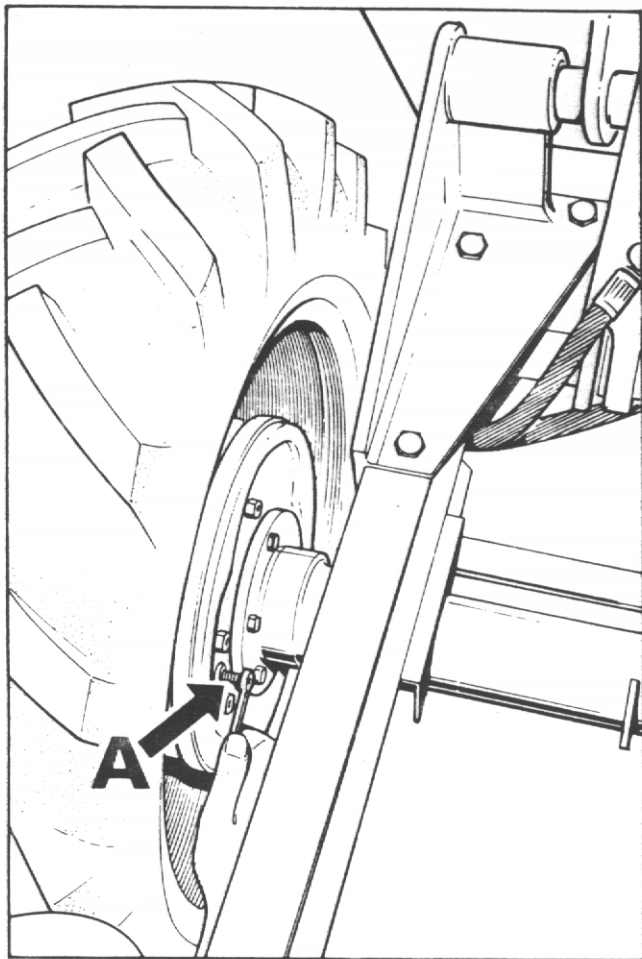

FIG. 4

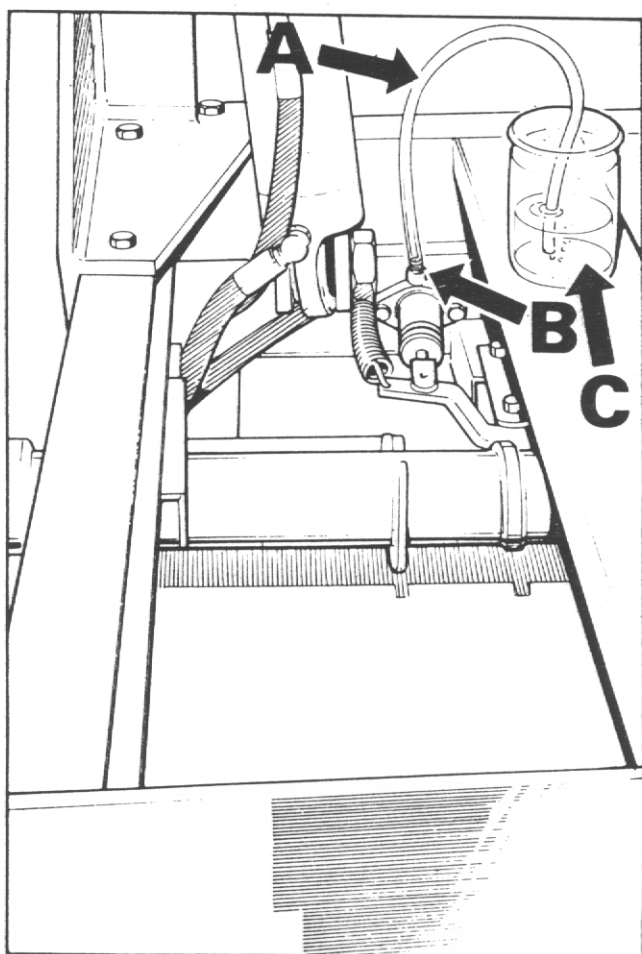

FIG. 5

## Hydraulic System

The single hydraulic pump provides power for both the skip operation and steering. The pump output is split into two circuits with priority flow to steering circuit which incorporates a flow control valve. If the hydraulic system fails to operate completely or does so extremely slowly carry out the following procedure.

1. Check that hydraulic tank is full of oil.
2. Check that hydraulic filter is not blocked. (See Fig. 6).
  - a) Remove the four setscrews (A) that secure the filler cap assembly (B) and remove assembly.
  - b) Unscrew suction filter (C) from inside tank (D) and wash in white spirit. Dry with moisture-free compressed air.
  - c) Replace suction filter and filler cap assembly.

NOTE:— If suction filter cannot be thoroughly cleaned, fit a new one.

3. Check that the hydraulic pressures are correct.

Tip circuit.

- a) Fit a 2000 lb./sq. in. gauge into the hydraulic system at the base of the skip ram.
- b) Operate control lever to dump skip and check that pressure reading on gauge is 1000 lb./sq.in. when ram is fully extended and relief valve is "blowing".

Steering circuit.

- a) Fit a 2000 lb./sq.in. gauge into the hydraulic system at the base of the steering ram.
- b) Turn steering wheel with machine on "full lock" and check that the reading on the gauge is 1000 lb./sq.in.

NOTE:— If correct pressure is not attained:—

Tip circuit.

4. Remove relief valve cartridge (A) (hexagon head) from the bottom of the control valve (B) (See Fig. 7), and replace with new one.
5. Remove hose adaptor (C) from control valve (See Fig. 7), remove hexagonal orifice plate (D) and wash in white spirit. Dry using moisture-free compressed air. DO NOT poke wire etc. into the orifice. Re-fit plate and hose adaptor with slot of orifice plate facing outwards.

Steering circuit

6. Remove relief valve cartridge (A) (hexagon head) from the bottom of the control valve (B) (See Fig. 7), and replace with new one.
7. Replace flow control valve (E) (See Fig. 7).

If none of these procedures correct the fault contact your Winget agent. Periodically check the hose between the pump and the tank to ensure it is not deformed. Any deformation in the hose may result in restricted flow of fluid and damage to the pump.

**IMPORTANT:— ON NO ACCOUNT SHOULD THE STEERING VALVE BE DISMANTLED, SHOULD IT REQUIRE ATTENTION REMOVE IT COMPLETE AND RETURN IT TO THE FACTORY.**

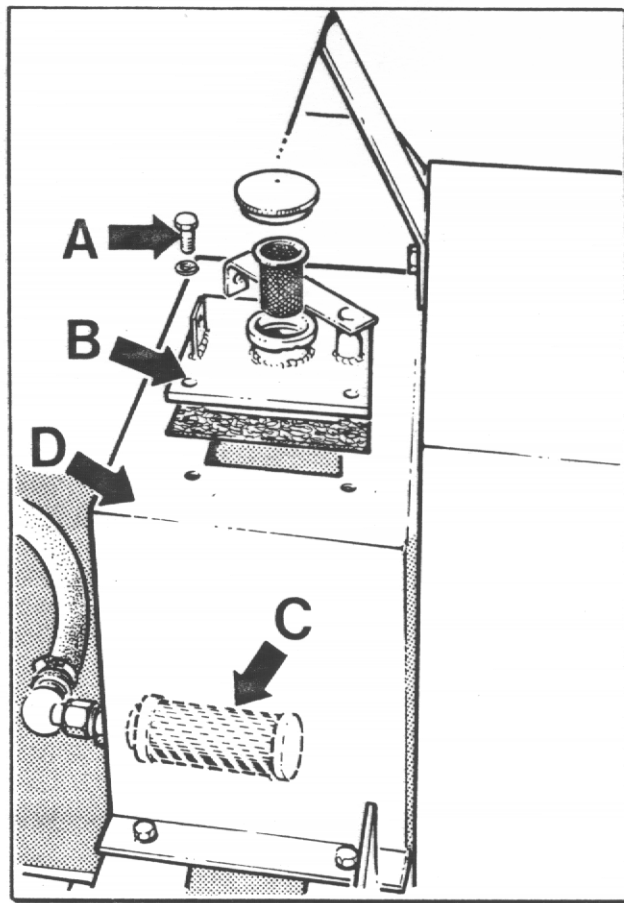

FIG. 6

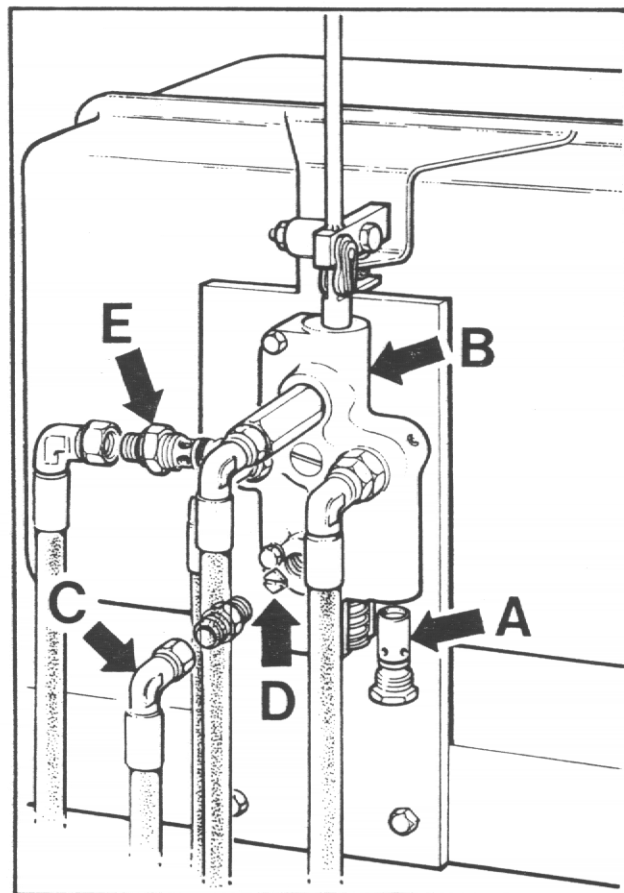

FIG. 7

## SPECIFICATION FOR MACHINE WITH HYDRAULIC FORWARD TIP SKIP

### Key to Fig. 8

A	Overall length	11 ft. 1 7/8 in.	(3400 mm)
B	Overall width	5 ft. 5 in.	(1650 mm)
C	Overall height	6 ft. 3 1/2 in.	(1918 mm)
D	Overall height when tipped	6 ft. 1 1/2 in.	(1867 mm)
E	Wheelbase	5 ft. 7 1/4 in.	(1708 mm)
F	Skip loading height	3 ft. 11 1/2 in.	(1206 mm)
G	Skip ground clearance when tipped	8 in.	( 203 mm)
H	Skip discharge	1 ft. 6 1/2 in.	( 470 mm)
J	Overhang	2 ft. 10 1/2 in.	( 876 mm)
K	Wheeltrack	4 ft. 7 in.	(1400 mm)
L	Prow width	4 ft. 1 1/4 in.	(1250 mm)
M	Ground clearance	9 1/2 in.	( 240 mm)

### Skip Capacity

Water level	27 cu.ft
Struck level	34 cu.ft
Heaped level	44 cu.ft
Max. Payload	30 cwt.

### Road speeds at 1650 r.p.m.

	mph.	kph.
1st	2.1	3.5
2nd	5.0	8.1
3rd	9.3	15.0
Rev.	2.4	3.9

### Miscellaneous

Min. Turning circle	23 ft. 6 in.	(7163 mm)
Unladen weight	31 cwt	(1576 kgs)
Hydraulic tank capacity	6 galls	(27 litres)
Fuel tank capacity	4 galls	(18 litres)
Rear axle articulation	11 in.	(280 mm)

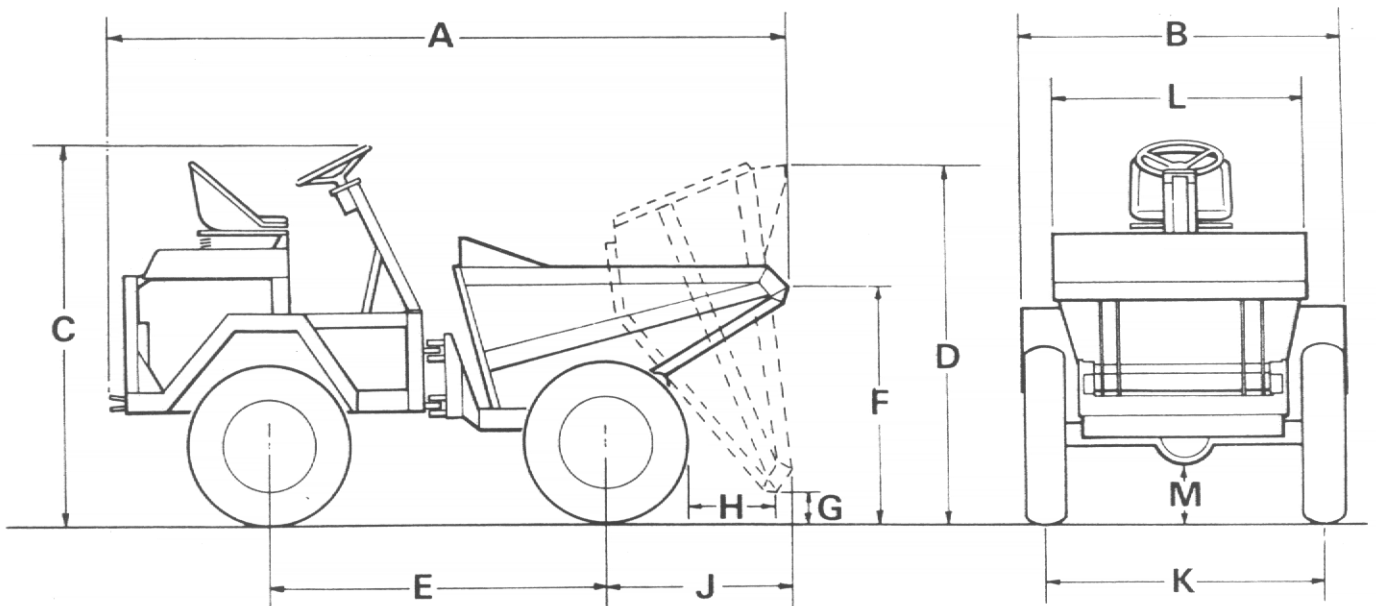

TP 207

FIG.8



**RECOMMENDED LUBRICATING OILS**

Company	Engine Petter	Transfer Box & Drive Axle	Gearbox	Wheel Bearings & Other Grease Points	Hydraulic System
(U.K.) <b>ESSO</b> Above 90°F 32-90°F (Overseas) Below 32°F	Estor HD 20  Essolube HD 30 Essolube HD 20 Essolube HD 10W	Esso Gear Oil GP 90/140  Esso Gear Oil GP 90/140 Esso Gear Oil GP 90/140 Esso Gear Oil GP 80	Estor HD 30  Essolube HD 30	Beacon 2  Beacon 2	Nuto H 44
(U.K.) <b>CASTROL</b> Above 90°F 32-90°F (Overseas) Below 32°F	Deusol CRI 20  Deusol CRI 30 Deusol CRI 20 Deusol CRI 10	Deusol Gear EP 90  Deusol Gear EP 140 Deusol Gear EP 90 Deusol Gear EP 80	Deusol CRI 30  Deusol CRI 30	Castrol Spheerol APT 2  Castrol Spheerol APT 2	Castrol Hyspin AWS 32
(U.K.) <b>SHELL</b> Above 90°F 32-90°F (Overseas) Below 32°F	Rotella S Oil 20/20W  Rotella S Oil 30 Rotella S Oil 20/20W Rotella S Oil 10W	Spirax 90 EP  Spirax 140 EP Spirax 90 EP Spirax 80 EP	Rotella S Oil 30  Rotella S Oil 30	Retinax A  Retinax A	Tellus Oil 27
(U.K.) <b>BP</b> Above 90°F 32-90°F (Overseas) Below 32°F	Energol DD 20W  Energol DD 30 Energol DD 20W Energol DD 10W	BP Gear Oil SAE 90EP  BP Gear Oil SAE 140 EP BP Gear Oil SAE 90 EP BP Gear Oil SAE 80 EP	Energol DD 30  Energol DD 30	Energrease L2  Energrease L2	Energol HL 65
(U.K.) <b>MOBIL</b> Above 90°F 32-90°F (Overseas) Below 32°F All Temperatures	Mobil Delvac Special or Mobil Delvac 1120  Mobil Delvac 1130 Mobil Delvac 1120 Mobil Delvac 1110 Mobil Delvac Special	Mobilube GX 90  Mobilube GX 140 Mobilube GX 90 Mobilube GX 80	Mobil Delvac 1130  Mobil Delvac 1130	Mobilgrease MP  Mobilgrease MP	Mobil DTE Oil Light

IN THE UNLIKELY EVENT OF THE ABOVE OILS NOT BEING AVAILABLE  
EQUIVALENT OILS SUPPLIED BY A REPUTABLE MANUFACTURER MAY BE USED

# SPARE PARTS SECTION

## LIST OF CONTENTS

Title	Page No.
CHASSIS . . . . .	18, 19
MUDWINGS & COVERS. . . . .	20, 21
HIGH DISCHARGE SKIP & FRAME . . . . .	22, 23
TURNTABLE SKIP, FRAME & CATCH. . . . .	24, 25
FORWARD TIP SKIP . . . . .	26
FLYWHEEL & CLUTCH ASSEMBLY . . . . .	27
GEARBOX . . . . .	28 – 31
TRANSFER BOX & PROP SHAFTS . . . . .	32, 33
DRIVE AXLE . . . . .	34 – 37
DRIVE WHEEL . . . . .	38
HANDBRAKE UNIT . . . . .	39
DRUM BRAKE ASSEMBLY . . . . .	40, 41
BRAKE PIPES & CONNECTIONS . . . . .	42, 43
BRAKE MASTER CYLINDER . . . . .	44
BRAKE SLAVE CYLINDER ASSEMBLY . . . . .	45
HANDBRAKE, VALVE CONTROL LEVER & ENGINE STOP CONTROL . . . . .	46, 47
PEDALS & CONTROLS . . . . .	48, 49
HYDRAULIC PIPES & FITTINGS . . . . .	50, 51
HYDRAULIC PUMP & DRIVE . . . . .	52
HYDRAULIC RAM. . . . .	53
HYDRAULIC CONTROL VALVE . . . . .	54, 55
HIGH DISCHARGE HYDRAULIC RAM . . . . .	56
AIR CLEANER . . . . .	57

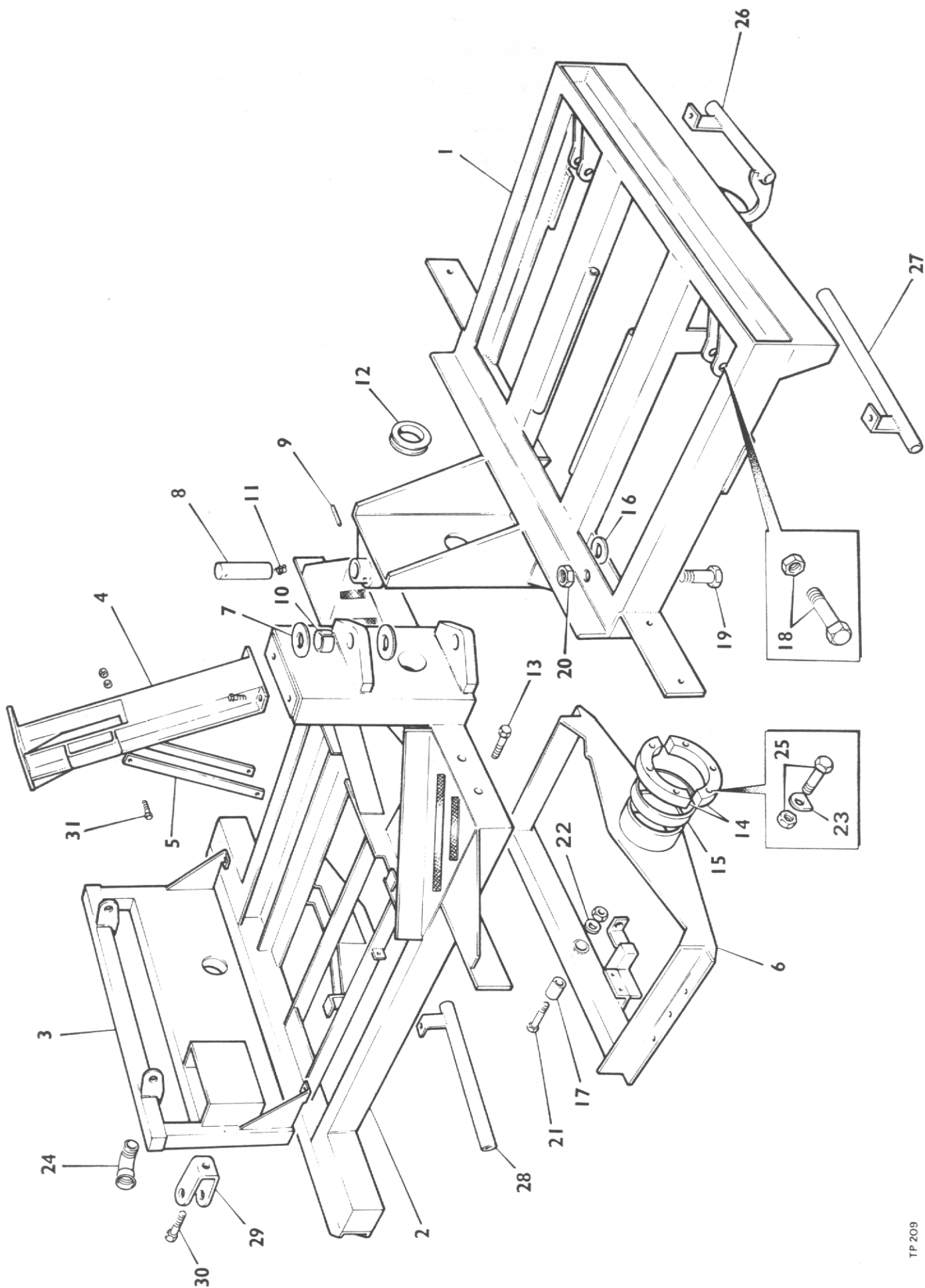

## CHASSIS

Item No.	Part No.	Description	Qty.
1	BSE 205	Front Chassis Turntable . . . . .	1
		Front Chassis High Discharge . . . . .	1
	BSE 133	Front Chassis Fwd. Hyd. Tip . . . . .	1
2	BSE 164	Rear Chassis. . . . .	1
3	BSE 204	Rear Frame . . . . .	1
4	CSE 107	Steering Column . . . . .	1
5	4-35-333	Steering Column Brace . . . . .	2
6	BSE 101	Articulating Axle Carrier . . . . .	1
7	4-35-29C	Thrustwasher - Centre Pivot . . . . .	4
8	4-35-29	Centre Pivot Pin . . . . .	2
9	4-35-29A	Tension Pin 5/16 in. Dia x 2¼ in. Long . . . . .	2
10	4-35-29B	Centre Pivot Pin Bush . . . . .	2
11	T90	Grease Nipple . . . . .	2
12	F4-45-182	Grommet . . . . .	2
13		Bolt M12 x 45mm Long & Locknut . . . . .	2
14	4-35-27	Axle Bearing Carrier . . . . .	1
15	4-35-26	Axle Carrier Bearing . . . . .	1
16	F4-45-50	Spacer . . . . .	1
17	E2245	Pivot Bush . . . . .	1
18	4-35-110A	Bolt-Steering Ram & Skip Ram (See Page 26) . . . . .	5
19	F4-45-57	Bolt-Steering Ram . . . . .	1
20	4-35-110B	Nut . . . . .	2
21		Nut & Bolt 7/8 in. BSF x 4 in. Long . . . . .	1
22		Washer 7/8 in. Dia. . . . .	1
23	4-35-145	Axle Bearing Carrier Tab Washer . . . . .	4
24	CSE 141	Elbow 1½ in. BSP M & F x 45° . . . . .	1
25		Bolt ½ in. BSF x 2¼ in. Long & Nut . . . . .	6
26	ASE 134 L.H.	Front L.H. & Rear R.H. Brake Rod Guard . . . . .	2
27	ASE 134 R.H.	Front R.H. Brake Rod Guard . . . . .	1
28	BSE 105	Rear L.H. Brake Rod Guard . . . . .	1
29	ASE 195	Tow Bracket . . . . .	1
30	8S.5D	Bolt M12 x 40 Long . . . . .	1
	61S.5	Nut, Self Locking . . . . .	1
31	8S.4D	Bolt M10 x 40 Long . . . . .	1
	61S.4	Nut, Self Locking . . . . .	1
	BSE 213	Front Stabiliser Weight (52 Kg.) . . . . .	1
	BSE 214	Front Stabiliser Weight ( 9 Kg.) . . . . .	1
	8S.6R	Bolt, M16 x 120 Long (Not illustrated) . . . . .	2
	61S.6	Nut, Self Locking (Not illustrated) . . . . .	2
	7S.5	Nut, M12 (Not illustrated) . . . . .	2
	59S.4	Nut, Self Locking M12 (Not illustrated) . . . . .	2
	10549.A01	Slave Cylinder Guard (Not illustrated) . . . . .	1
	8S.4B	Bolt (Not illustrated) . . . . .	2
	61S.4	Nut, Self Locking (Not illustrated) . . . . .	2
	12S.5	Washer, Plain (Not illustrated) . . . . .	2
	105S.3	Taper Washer (5°) (Not illustrated) . . . . .	2

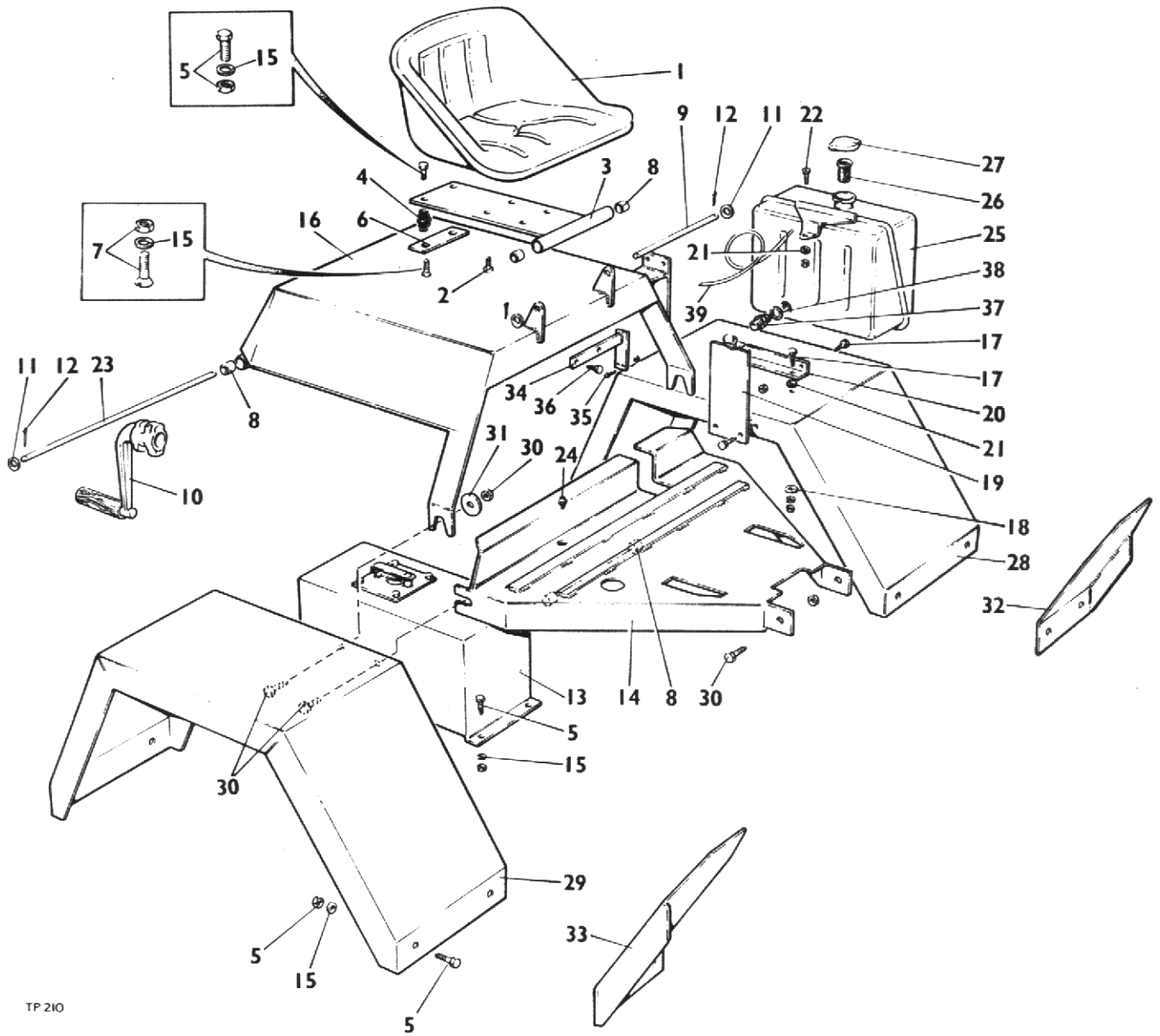

## MUDWINGS AND COVERS

Item No.	Part No.	Description	Qty.
1	4-35-301	Seat . . . . .	1
2		Seat Bolts 8mm x 20mm Long Mush. Head . . . . .	4
3	CSE 116	Seat Frame . . . . .	1
4	5ST 99	Seat Spring . . . . .	2
5		Bolt M10 x 25mm Long & Locknut . . . . .	18
6	4-35-331	Seat Spring Plate . . . . .	1
7		Bolt csk. M10 x 25mm Long & Locknut . . . . .	2
8	WB0808	Bush . . . . .	4
9	4-35-307	Seat Pivot Rod . . . . .	1
10	C188	Starting Handle . . . . .	1
11		Flat Washer 12mm dia. . . . .	4
12		Split Pin 3/32 in. dia x 1 in. Long . . . . .	4
13	CSE 123	Hydraulic Tank . . . . .	1
14	BSE 165	Footplate . . . . .	1
15		Flat Washer 10mm dia . . . . .	20
16	BSE 160	Engine Cover . . . . .	1
17		Bolt M8 x 25mm Long & Locknut . . . . .	4
18		Flat Washer 8mm dia . . . . .	6
19	F4-45-173	Hydraulic Valve Mounting Bracket (See page 47) . . . . .	1
20	CSE 170	Angle . . . . .	1
21	CSE 158	Rubber Bush . . . . .	3
22		Bolt M6 x 30mm Long & Locknut . . . . .	1
23	CSE 168	Pivot Pin . . . . .	1
24	T-ST	Grease Nipple . . . . .	1
25	BAE 7E	Fuel Tank . . . . .	1
26	JE 13	Strainer . . . . .	1
27	CE 12	Cap . . . . .	1
28	BSE 162	Left Hand Mudwing . . . . .	1
29	BSE 161	Right Hand Mudwing . . . . .	1
30		Bolt M12 x 40mm Long & Locknut . . . . .	6
31	CSE 167	Blanking Plate . . . . .	2
32	2ST 78	Left Hand Mudflap . . . . .	1
33	2ST 77	Right Hand Mudflap . . . . .	1
34	BSE 104	Fuel Filter Support Bracket . . . . .	1
35		Bolt 1/4" BSF x 1" Long & Nut . . . . .	2
36		Setscrew 5/16" BSF x 3/4" Long . . . . .	2
37	4-60-189	Adaptor 3/8" BSP x 1/4" BSP . . . . .	1
38	4-35-364	Fibre Washer . . . . .	1
39	258721	Leak Back Tube 18" Long . . . . .	1

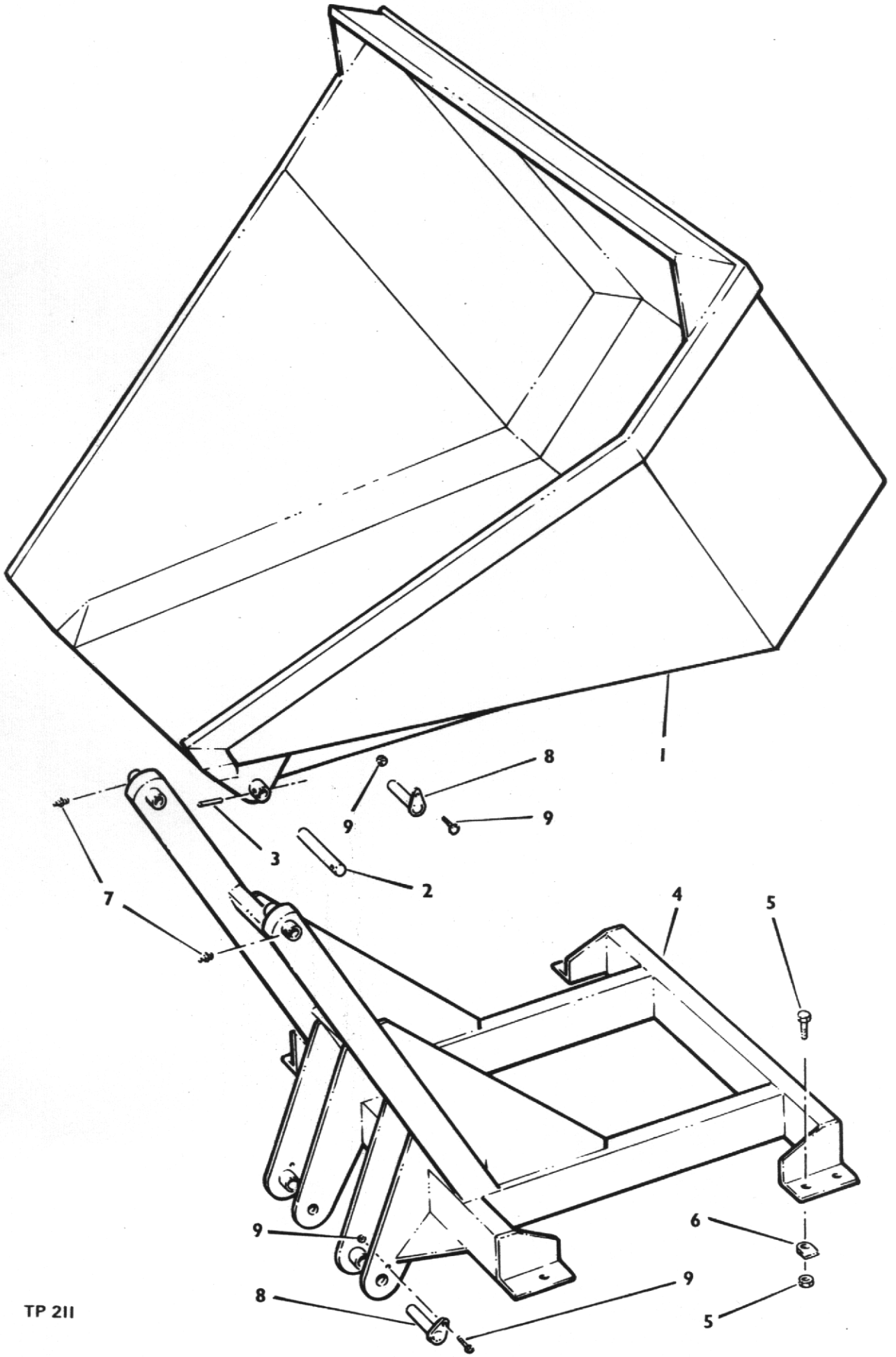

TP 211

## HIGH DISCHARGE SKIP AND FRAME

Item No.	Part No.	Description	Qty.
1	4-35-210	Skip . . . . .	1
2	5ST 84	Skip Pivot Pin . . . . .	2
3	4-35-29A	Tension Pin 5/16 in. Dia.x 2¼ in. Long . . . . .	2
4	BSE 146	Frame . . . . .	1
5		Bolt ½ in. BSF x 1½ in. Long . . . . .	6
6		Taper Washer ½ in. Dia. . . . .	6
7	5ST 100	Grease Nipple . . . . .	2
8	4-35-178	Ram Pin . . . . .	4
9		Bolt 5/16 in. BSF x 1 in. Long & Nut . . . . .	4



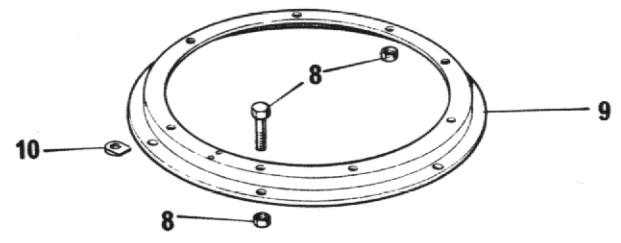
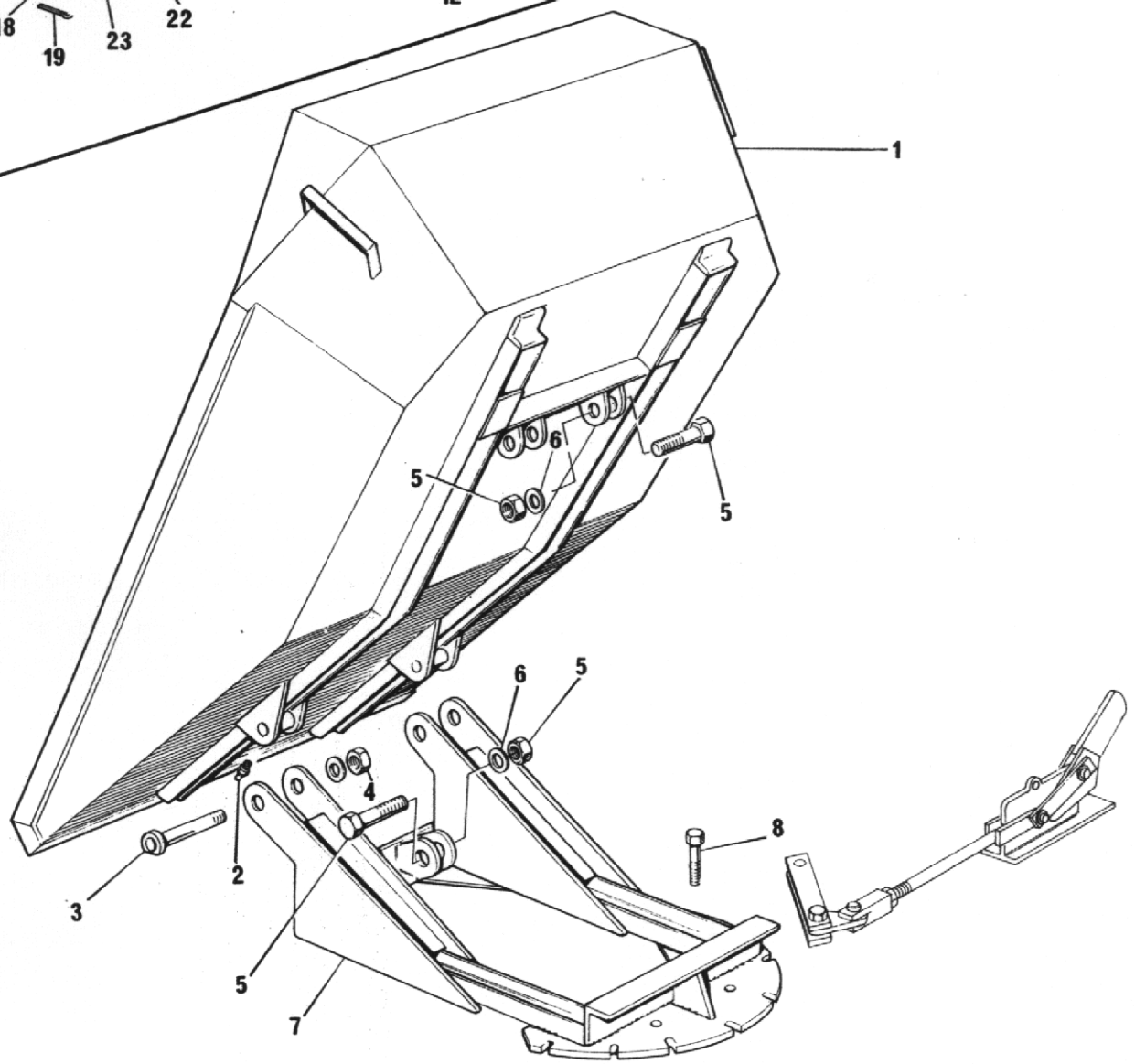
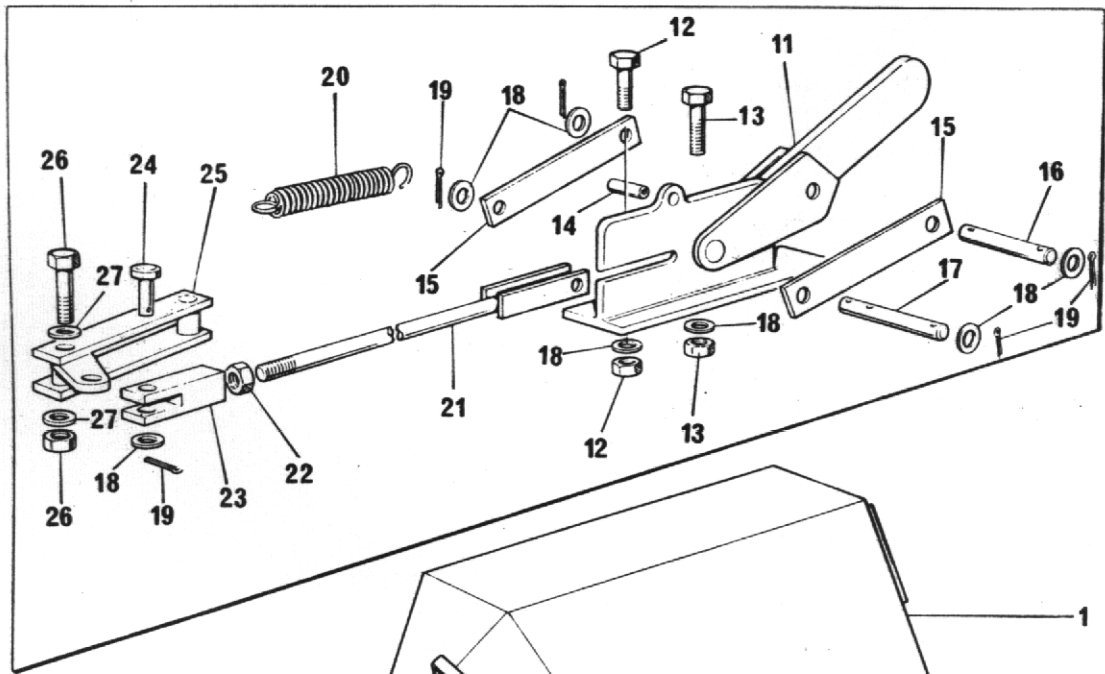

## SKIP, TURNTABLE AND CATCH

Item No.	Part No.	Description	Qty
1	ASE 104	Skip . . . . .	1
2	TS	Grease Nipple . . . . .	2
3	2ST 137	Skip Pivot Pin . . . . .	2
4		Nut 3/8 in. UNF . . . . .	2
5	4-35-110	Bolt and Nut . . . . .	4
6		Lock Washer 1/4" Dia. . . . .	4
7	ASE 105	Turntable Frame . . . . .	1
8		Bolt 1/2" BSF x 1 1/2" Long and Nut . . . . .	12
9	ASE 197	Turntable Bearing Ring . . . . .	1
10		Taper Washer 1/2" Dia . . . . .	2
11	ASE 150	Catch Lever Assembly . . . . .	1
12		Bolt 1/2" BSF x 1 1/2" Long and Nut . . . . .	1
13		Bolt 1/2" BSF x 2" Long and Nut . . . . .	1
14	6R.P./16	Tension Pin . . . . .	1
15	2ST 112-5	Link . . . . .	2
16	2ST 115	Pin . . . . .	1
17	2ST 114	Pin . . . . .	1
18		Flat Washer 1/2" Dia . . . . .	7
19		Split Pin 3/32" Dia. . . . .	5
20	C173B	Spring . . . . .	1
21	ASE 145	Rod Assembly . . . . .	1
22		Nut 1/2" BSF . . . . .	1
23	C174H	Clevis . . . . .	1
24	WT178-7	Clevis Pin . . . . .	1
25	2ST 112-B	Bell Crank Assembly . . . . .	1
26		Bolt 5/8" UNF x 3 1/2" Long and Selflock Nut . . . . .	1
27		Flat Washer 5/8" Dia. . . . .	2

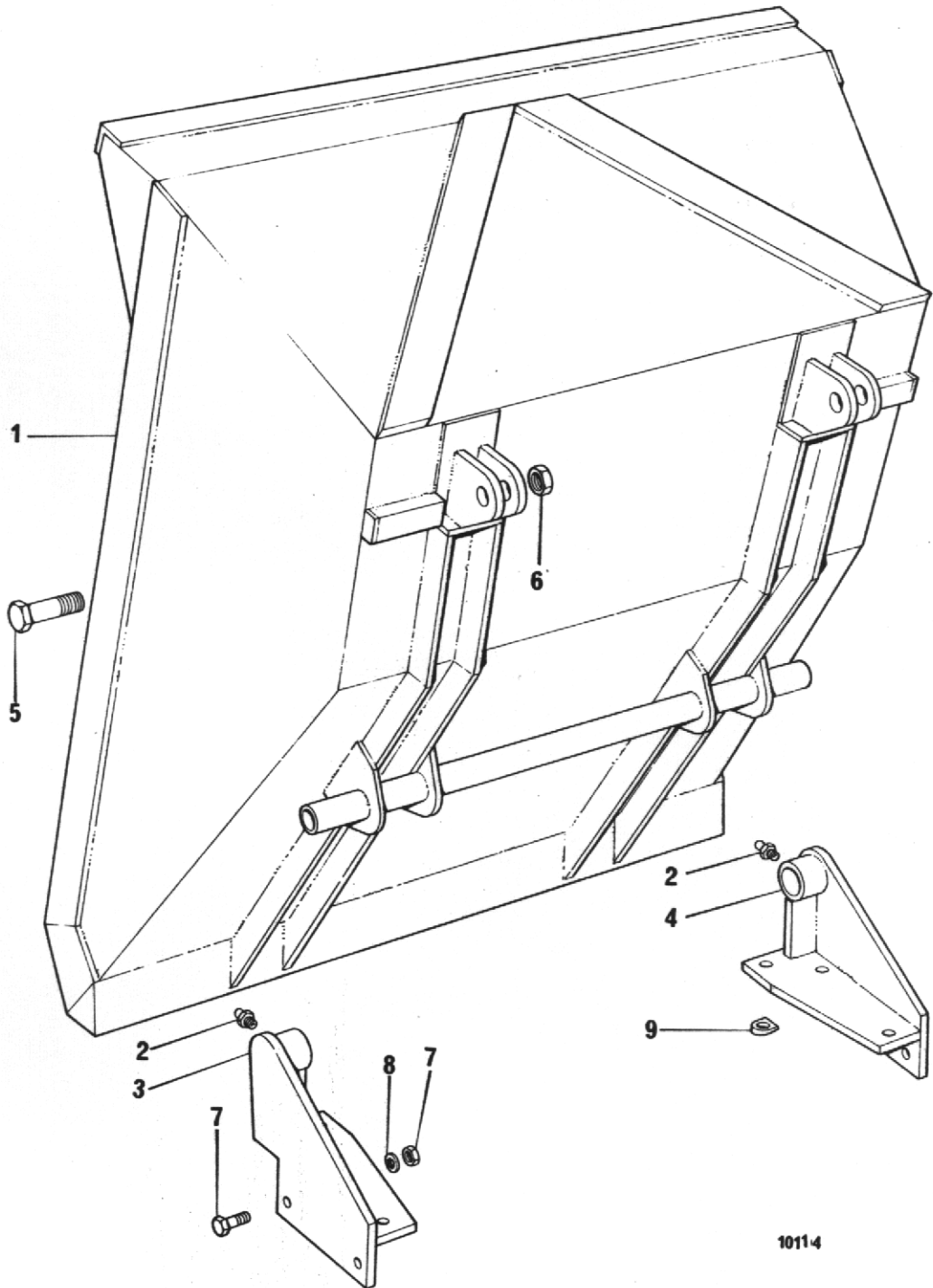

10114

### HYDRAULIC TIP SKIP

Item No.	Part No.	Description	Qty.
1	BSE 201	Skip . . . . .	1
2	5ST 100	Grease Nipple . . . . .	2
3	ASE 107	Skip Mounting Bracket L.H. . . . .	1
4	ASE 108	Skip Mounting Bracket R.H. . . . .	1
5	4-35-110A	Bolt . . . . .	4
6	4-35-110B	Nut . . . . .	4
7		Bolt ½ in. BSF x 1½ in. Long & Nut. . . . .	10
8		Taper Washer ½ in. . . . .	6

## FLYWHEEL AND CLUTCH ASSEMBLY

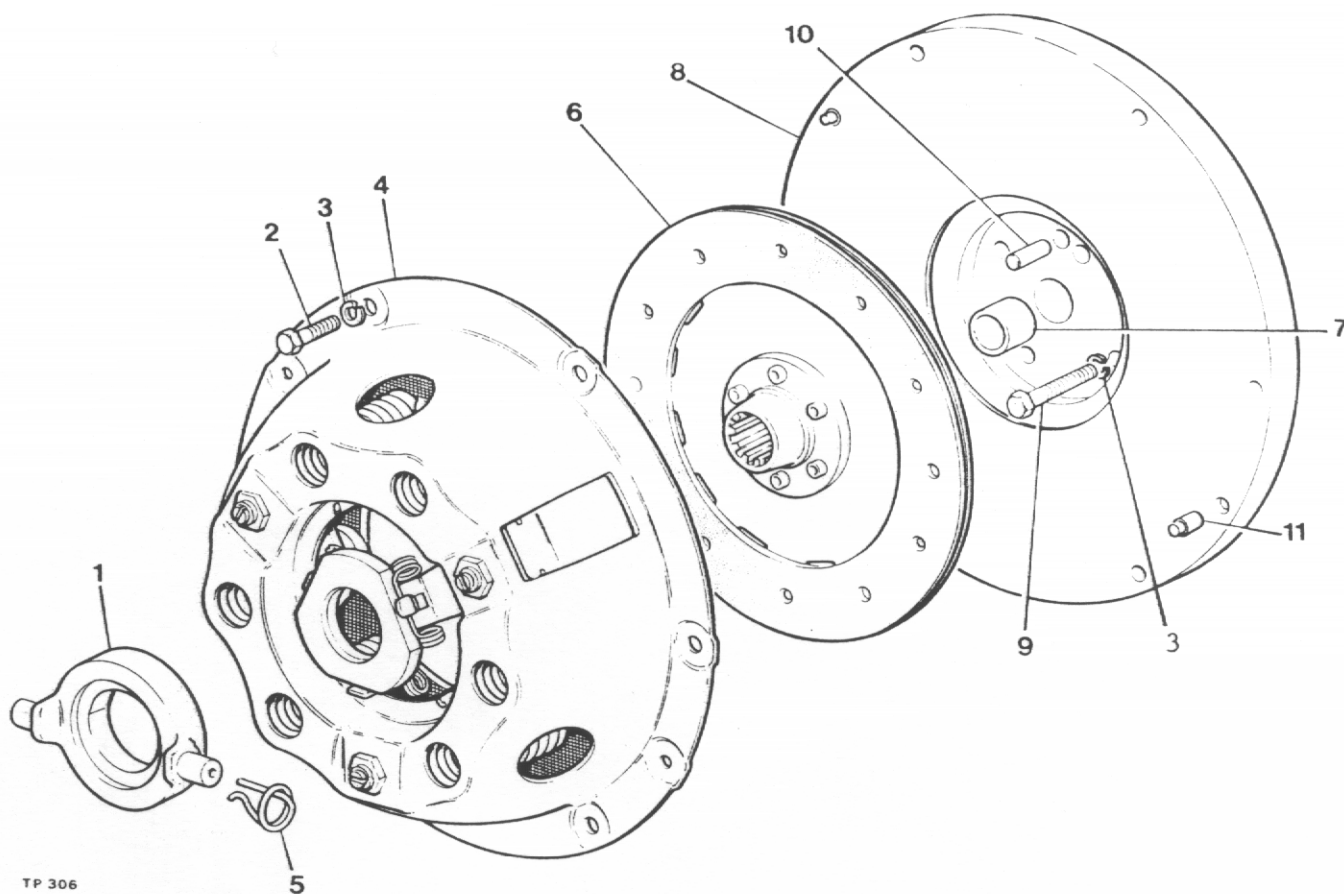

TP 306

Item No.	Part No.	Description	Qty.
1	10579A01	Clutch Release Bearing	1
2	28S02D	Screw Set	6
3	41S04	Washer Spring	10
4	10597A01	Cover Assembly	1
5	10579A101	Retainer Spring	2
6	10598A02	Drive Plate	1
7	10580A0101	Bush	1
8	10580A02	Flywheel Assembly (comprises of items 7, 8, & 11)	1
9	1S02C	Bolt, Petter PH Engine (drill for locking wire)	4
9A	6S02B	Bolt, Lister Engine (drill for locking wire)	4
10	C321	Dowel	1
11	10580A0102	Dowel	2
	10948A02	Clutch Kit (comprises of items 1, 4, 5 & 6)	1

It is recommended that instead of drilling the head of the bolts (item 9) for locking wire that one of each of tabwashers part no's 10531A02 and 10531A03 are used to prevent the bolts working loose.

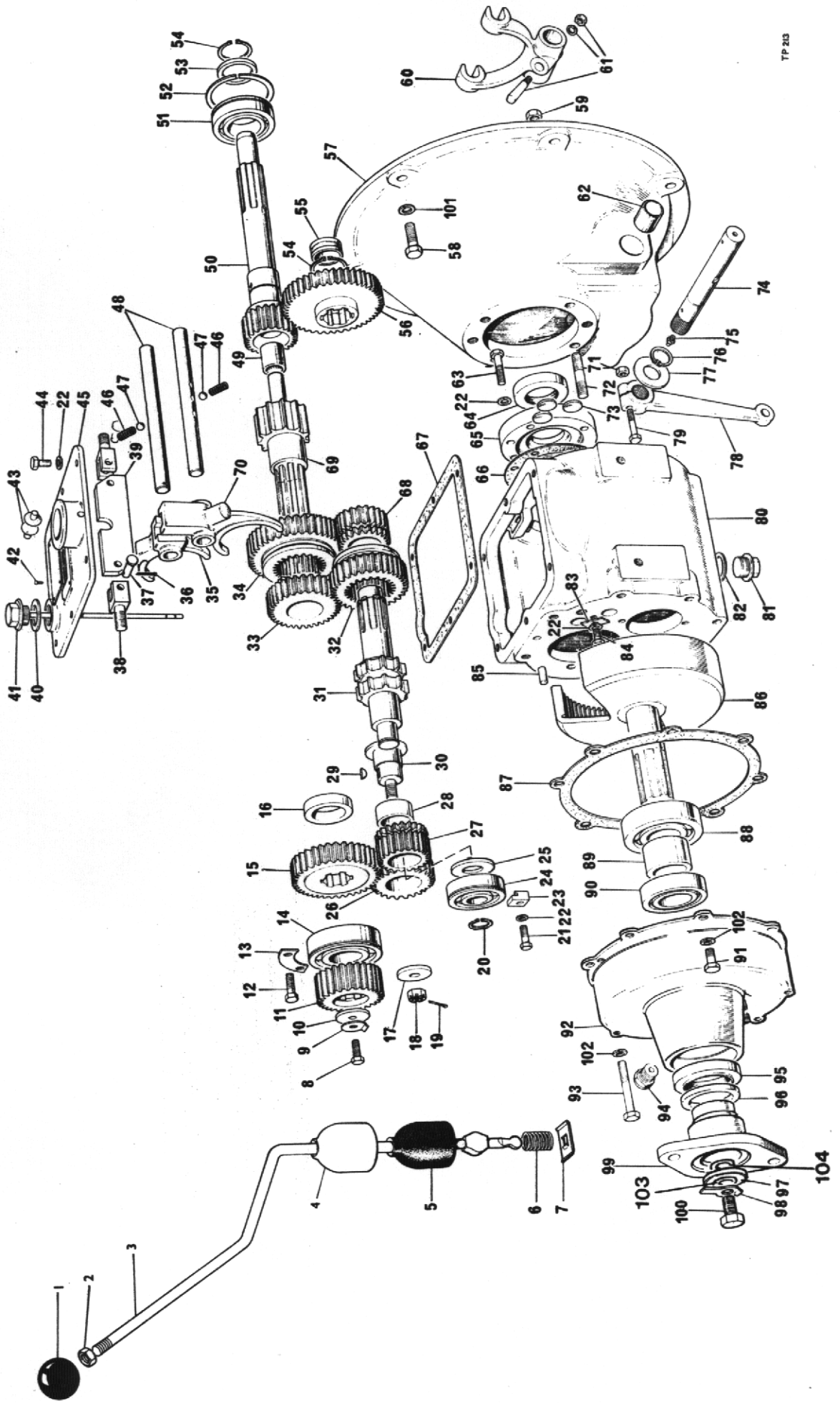

GEARBOX 40M-42-583 INV. -372

Item No.	Part No.	Description	Qty.
1	40M/133	Knob, Gear Lever . . . . .	1
2	UN 512	Locknut, Gear Lever . . . . .	1
3	40M/372	Gear Lever . . . . .	1
4	40M/377	Cap, Gear Lever . . . . .	1
5	40M/129	Cover, Gear Lever . . . . .	1
6	40M/367	Spring, Gear Lever . . . . .	1
7	40M/245	Retaining Plate, Gear Lever . . . . .	1
8	USF 53	Screw, Mainshaft . . . . .	1
9	40M/179	Lockwasher - Tab . . . . .	1
10	40M/178	Washer, Reduction Pinion . . . . .	1
11	40M125	Reduction Pinion (Petter) . . . . .	1
12	USF 11	Screw, Bearing Retainer . . . . .	2
13	40M/378	Bearing Retainer, Small . . . . .	1
14	CM/2052	Bearing, Mainshaft Rear . . . . .	1
15	40M/110	Output Gear . . . . .	1
16	40M/128	Spacer, Output Gear . . . . .	1
17	40M/155	Washer, Reverse Pinion Shaft . . . . .	1
18	UN 507	Nut, Reverse Spindle . . . . .	1
19	CP/1004	Split Pin . . . . .	1
20	40M/148	Circlip . . . . .	1
21	USF/31	Screw . . . . .	2
22	W104	Spring Washer . . . . .	16
23	40M/299	Clip, Layshaft Bearing . . . . .	2
24	40M/146	Layshaft Bearing . . . . .	2
25	40M/130	Bearing Spacer . . . . .	1
26	40M/111	Reverse Pinion . . . . .	1
27	40M/114	Reverse Speed Gear . . . . .	2
28	40M/161	Bush, Reverse Pinion . . . . .	1
29	40M/222	Key, Reverse Pinion Shaft . . . . .	1
30	40M/119	Shaft, Reverse Pinion . . . . .	1
31	40M/118	Layshaft . . . . .	1
32	40M/116	2nd Speed Sliding Gear . . . . .	1
33	40M/113	Second Speed Gear . . . . .	1
34	40M/115	1st Speed Gear . . . . .	1
35	40M/502	Selector Fork, 2nd & 3rd. . . . .	1
36	40M/244	Split Pin, Interlock . . . . .	2
37	40M/232	Clevis Pin, Interlock. . . . .	2
38	40M/231	Stud, Interlock . . . . .	2
39	40M/505	Interlock Plate . . . . .	1
40	CP/1068	Seal, Dipstick . . . . .	1
41	40M/153	Dipstick . . . . .	1
42	CP/1003	Drive Screw . . . . .	4
43	40M/254	Pad, Gear Lever . . . . .	2
44	USF 21	Screw, Top Cover . . . . .	6
45	40M/220	Top Cover . . . . .	1
46	CM/2103	Detent Spring . . . . .	2
47	CM/1077	Detent Ball . . . . .	2
48	40M/135	Selector Shaft . . . . .	2
49	40M/513	Bearing, Primary Shaft. . . . .	1
50	40M/117	Primary Shaft . . . . .	1
51	40M/143	Input Bearing . . . . .	1
52	40M/252	Snap Ring . . . . .	1
53	40M/174	Bearing Spacer . . . . .	1

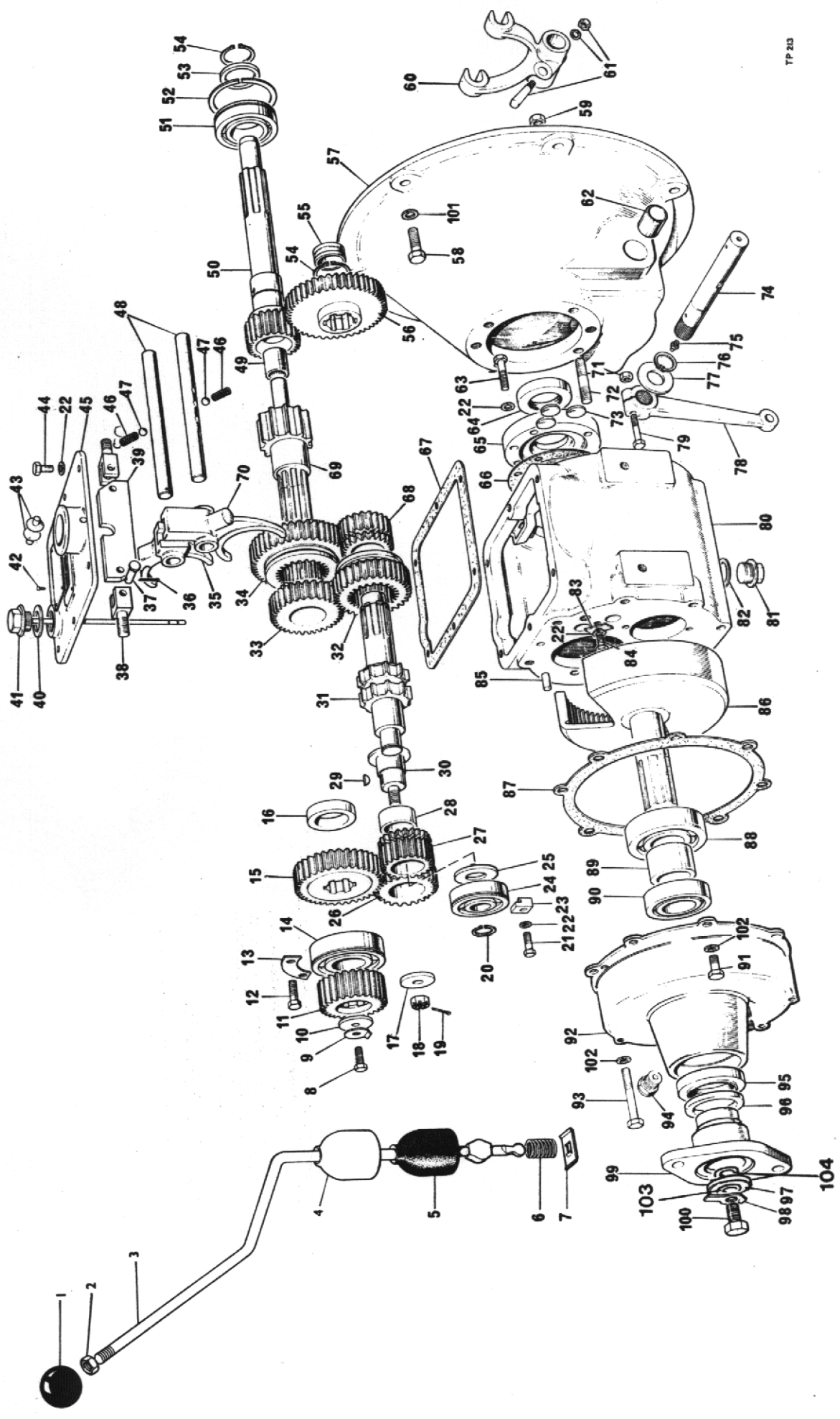

**GEARBOX 40M-42-583 INV. -372 (Continued)**

Item No.	Part No.	Description	Qty.
54	CM/2053	Circlip . . . . .	2
55	40M/162	Bush, Layshaft . . . . .	1
56	40M/360	1st Reduction Gear . . . . .	1
57	40M/392	Clutch Housing . . . . .	1
58		Bolt Clutch Housing 3/8" BSF x 1" Long - Petter . . . . .	6
59	UNL 106	Nut . . . . .	6
60	CM/2083	Clutch Release Fork . . . . .	1
61	CM/2084 S/A	Cotter, Nut and Washer S/A . . . . .	1
62	CM/2179	Bush, Cross Shaft . . . . .	2
63	UBF 71	Bolt, Front Cover . . . . .	4
64	40M/150	Oil Seal, Input . . . . .	1
65	40M/126	Front Cover . . . . .	1
66	40M/172	Joint, Front Cover . . . . .	1
67	40M/169	Joint, Top Cover . . . . .	1
68	40M/114	Reverse Speed Gear . . . . .	2
69	40M/515	Mainshaft . . . . .	1
70	40M/501	Selector Fork, 1st. and Reverse . . . . .	1
71	UN501	Nut, Clutch Lever . . . . .	1
72	40M/177	Stud, Clutch Housing . . . . .	6
73	CM/2113	Sealing Disc, Selector Shaft . . . . .	3
74	40M/394	Clutch Cross Shaft . . . . .	1
75	CP/1069	Grease Nipple . . . . .	2
76	CP/1006	Circlip . . . . .	1
77	40M/398	Washer, Cross Shaft . . . . .	1
78	CM/2090	Clutch Release Lever . . . . .	1
79	UBF 91	Bolt, Clutch Lever . . . . .	1
80	40M/101/M	Casing . . . . .	1
81	CP/1002	Drain Plug . . . . .	1
82	CP/1068	Seal, Drain Plug . . . . .	1
83	40M/136	Selector Locking Strip . . . . .	1
84	USF 21	Setscrew . . . . .	2
85	40M/656	Dowel . . . . .	2
86	40M/120	Internal Gear . . . . .	1
87	40M/654	Joint, Reduction Housing . . . . .	1
88	CM/2068	Bearing, Internal Gear Front . . . . .	1
89	40M/138	Spacer . . . . .	1
90	40M/149	Bearing, Internal Gear Rear . . . . .	1
91	USF 32	Hex. Head Screw . . . . .	5
92	40M/655	Reduction Housing . . . . .	1
93	UBF/142	Hex. Head Bolt . . . . .	3
94	CM/2106	Breather . . . . .	1
95	40M/167	Oil Seal, Rear . . . . .	1
96	CM/2537	Dust Shield . . . . .	1
97	CM/2123	Washer, Coupling . . . . .	1
98	CM/2050	Lock Washer . . . . .	1
99	40M/583	Coupling . . . . .	1
100	USF 55	Screw, Coupling . . . . .	1
101		Spring Washer 3/8" . . . . .	6
102		Spring Washer 5/16" . . . . .	8
103	CP 1098	Fibre Washer . . . . .	1
104	40M 340	Fibre Washer . . . . .	1



1  
—  
ASSY.

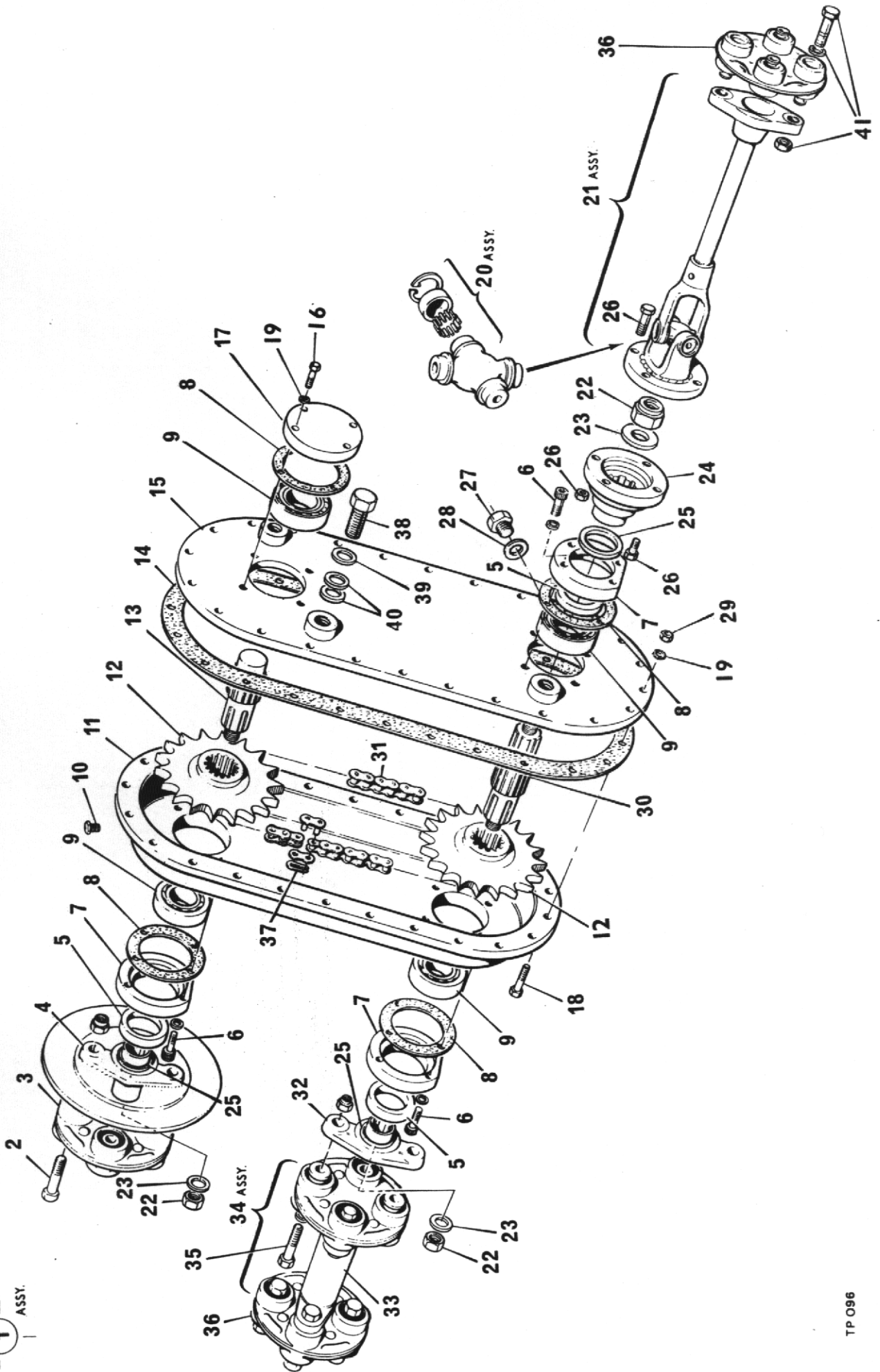

## TRANSFER BOX AND PROP SHAFTS

Item No.	Part No.	Description	Qty
1	ASE 142	Transfer Box Complete Including Item 4 . . . . .	1
2	10324.A01	Coupling Bolt, Washer and Nut . . . . .	4
3	10323.A01	Coupling . . . . .	1
4	4-35-400	Brake Disc . . . . .	1
5	40M 167	Oil Seal . . . . .	3
6	UFC 416	Cap Screw . . . . .	12
7	4-35-102	Oil Seal Housing . . . . .	3
8	CM.2073	Gasket . . . . .	4
9	CM.2068	Bearing . . . . .	4
10	CM.2106	Breather . . . . .	1
11	4-35-96	Main Case . . . . .	1
12	4-35-17	Chain Wheel 19 Tooth . . . . .	2
13	4-60-252	Input Shaft . . . . .	1
14	4-35-20	Joint . . . . .	1
15	4-35-97	Main Cover . . . . .	1
16	UBF 51	End Cover Screws . . . . .	4
17	CM 2528	Cover . . . . .	1
18	UBF 71	Housing Screw . . . . .	24
19		Spring Washer 1/4" dia . . . . .	28
20	03-501-346	Repair Kit	
21	BSE 134	Prop Shaft Assembly . . . . .	1
22		3/4" UNF Self Locking Nut . . . . .	2
23		3/4" Dia. Thick Washer . . . . .	3
24	40M/589	Companion Flange . . . . .	1
25	CM 2537	Dust Shield . . . . .	3
26	ESE 214	Prop Shaft Nut and Bolt 1 1/4" x 7/16" BSF . . . . .	4
27	CP.1002	Drain Plug . . . . .	1
28	CP.1068	Fibre Washer . . . . .	1
29	UN.501	Nut . . . . .	24
30	4-60-253	Output Shaft . . . . .	1
31	4-35-18	Drive Chain . . . . .	1
32	40M/580	Companion Flange . . . . .	1
33	L307	Prop Shaft . . . . .	1
34	10327.A01	Prop Shaft Assembly Complete . . . . .	1
35	10326.A01	Coupling Bolt, Washer and Nut . . . . .	10
36	10325.A01	Coupling . . . . .	3
37	4-35-18A	Connecting Link (Chain) . . . . .	1
38		Setscrew 1/2" BSF x 1 1/4" Long (Drilled for Wire Locking) . . . . .	3
39		Washer 1/2" . . . . .	3
40		Spacing Washers . . . . .	A.R.
41	10329.A01	Coupling bolt, washer & nut . . . . .	2

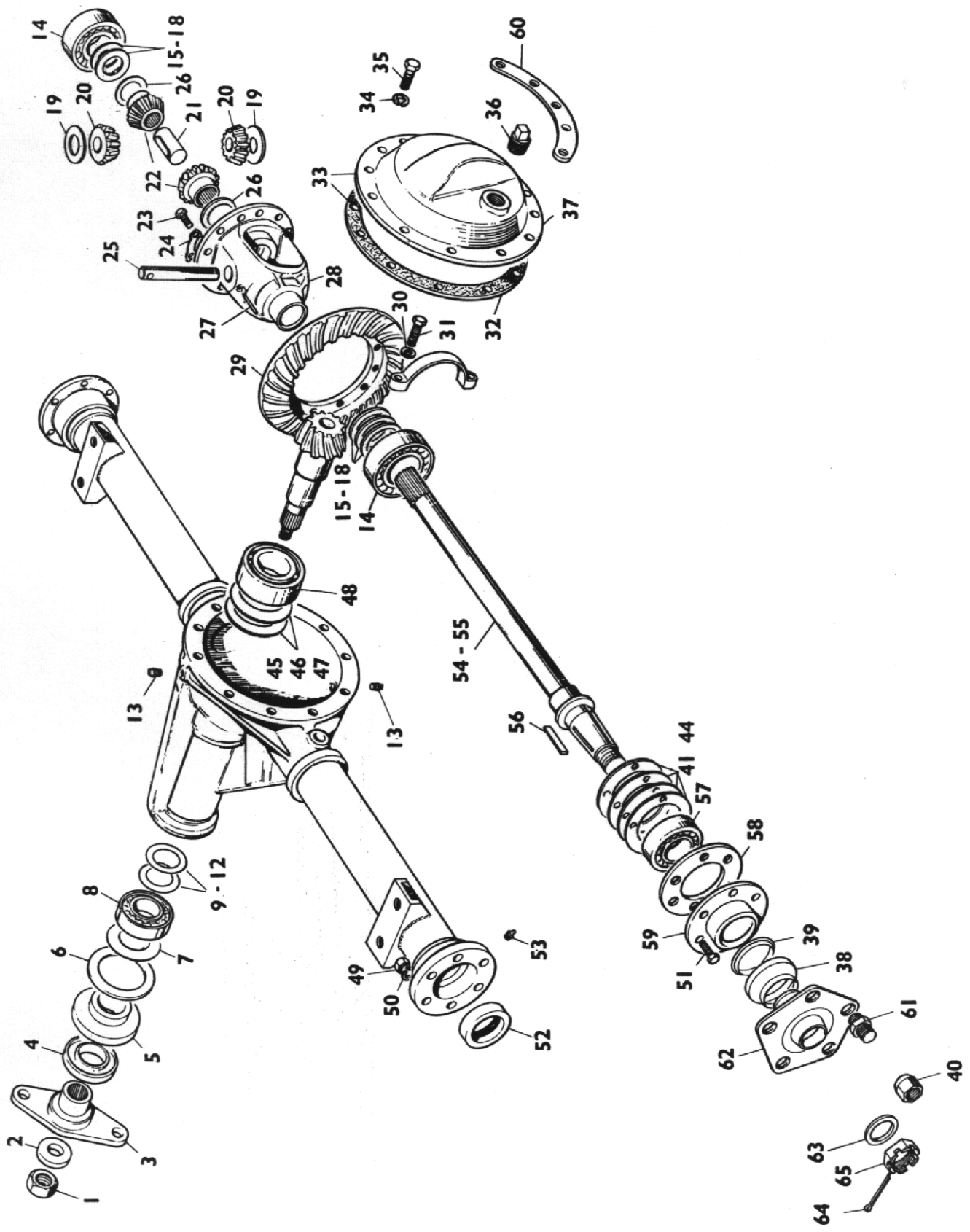

## DRIVE AXLE

Item No.	Part No.	Description	Qty.
	5HA-001-274	Drive Axle Complete with drum brakes (2 per m/c)	
1	12 LN-NF9	Pinion Nut . . . . .	1
2	12W-24	Pinion Nut Washer . . . . .	1
3	4HA-102-26	Companion Flange Assembly . . . . .	1
4	2HA-021	Companion Flange Dust Shield . . . . .	1
5	2HA-019	Pinion Oil Seal . . . . .	1
6	2HA-020	Pinion Oil Seal Gasket . . . . .	1
7	2HA-036	Pinion Oil Slinger . . . . .	1
8	5HA-022	Pinion Bearing, Outer . . . . .	1
9	5HA-039	Pinion Bearing Adjusting Shim Outer .003"	2
10	5HA-040	Pinion Bearing Adjusting Shim Outer .005"	2
11	5HA-041	Pinion Bearing Adjusting Shim Outer .010"	2
12	5HA-042	Pinion Bearing Adjusting Shim Outer .030"	1
13	HA-059	Filler and Drain Plug (each) . . . . .	1
14	5HA-024/1	Differential Bearing . . . . .	2
15	5HA-046	Differential Bearing Shim .003"	2
16	5HA-047	Differential Bearing Shim .005"	2
17	5HA-048	Differential Bearing Shim .010"	2
18	5HA-049	Differential Bearing Shim .030"	1
19	5HA-037	Differential Pinion Mate Thrustwasher . . . . .	2
20	5HA-008-1	Differential Pinion Mate . . . . .	2
21	5HA-033-3	Axle Shaft Spacer . . . . .	1
22	5HA-007-2	Differential Side Gear . . . . .	2
23	5HA-075-2	Drive Gear Screw . . . . .	12
24	5HA-074-1	Drive Gear Tabwasher . . . . .	6
25	5HA-012	Differential Pinion Mate Shaft . . . . .	1
26	5HA-038	Differential Side Gear Thrustwasher . . . . .	2
27	5HA-013	Differential Pinion Mate Shaft Lock Pin . . . . .	1
28	5HA-006	Differential Case . . . . .	1
29	5HA-105 15	Drive Gear and Pinion Assembly Complete . . . . .	1
30	8 LW-115	Differential Bearing Cap Washer - Spring . . . . .	4
31	8 B-NC 36	Differential Bearing Cap Bolt . . . . .	4
32	5HA-026	Gear Carrier Cover Gasket . . . . .	1
33	5HA-064-1	Gear Carrier Cover Assembly . . . . .	1
34	6LW-105	Cover Screw Washer - Spring . . . . .	10
35	6B-NC10	Cover Screw . . . . .	10
36	HA-059	Level Plug . . . . .	1
37	5HA-010	Gear Carrier Cover . . . . .	1
38	5HA-030-4	Shroud . . . . .	2
39	5HA-032-14	Seal . . . . .	2
40	DM 190	Wheel Nut . . . . .	10
41	5HA-050-3	Axle Shaft Bearing Shim .003"	2
42	5HA-051-3	Axle Shaft Bearing Shim .005"	2
43	5HA-052-3	Axle Shaft Bearing Shim .010"	2
44	5HA-053-3	Axle Shaft Bearing Shim .030"	2
45	5HA-043	Pinion Adjusting Shim, Inner .003"	2
46	5HA-044	Pinion Adjusting Shim, Inner .005"	2
47	5HA-045	Pinion Adjusting Shim, Inner .010"	2
48	5HA-023	Pinion Bearing Inner . . . . .	1
49	6N-NF5	Bearing Retainer Nut . . . . .	12
50	6W-12	Washer - Spring . . . . .	2
51	6B-NF 18/B	Bearing retainer bolt . . . . .	12
52	5HA-027	Axle Shaft Oil Seal . . . . .	2
53	5HA-056	Axle Shaft Bearing Grease Nipple . . . . .	2
54	5HA-005-51	Axle Shaft RH . . . . .	1
55	5HA-005-51	Axle Shaft LH . . . . .	1

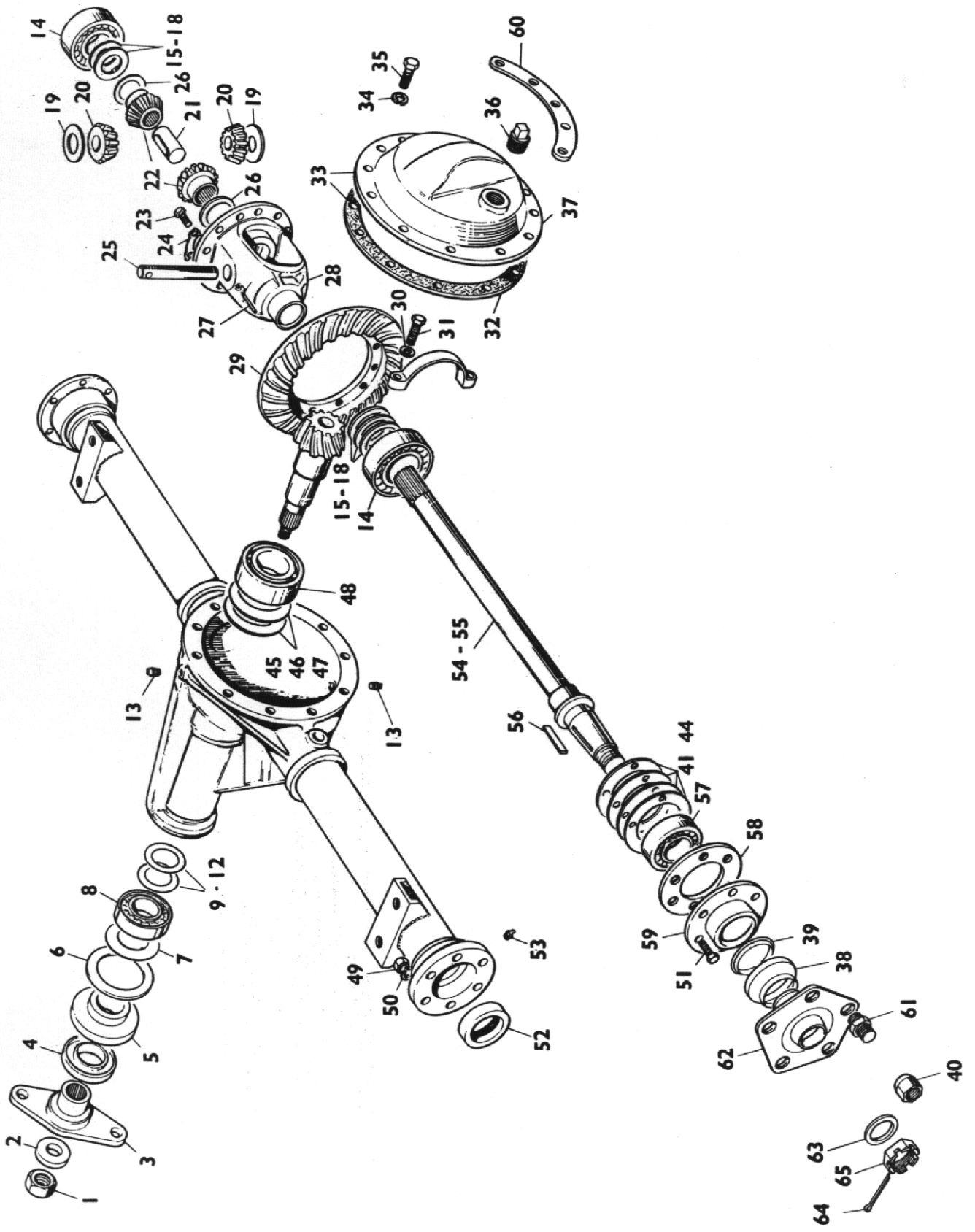

**DRIVE AXLE (Continued)**

Item No.	Part No.	Description	Qty.
56	5HA-029	Axle Shaft Key . . . . .	2
57	5HA-025	Axle Shaft Bearing . . . . .	2
58	5HA-035-5	Axle shaft bearing retainer . . . . .	2
59	5HA-057-1	Hub oil seal assembly . . . . .	2
60	4-35-235	Differential cover support . . . . .	1
61	5HA-055-6	Wheel stud . . . . .	10
62	5HA-028-37	Wheel hub complete . . . . .	2
63	18W-32	Axle shaft washer . . . . .	2
64	12SP-18	Axle shaft cotter . . . . .	2
65	18-SN-NF-12	Axle shaft Nut . . . . .	2

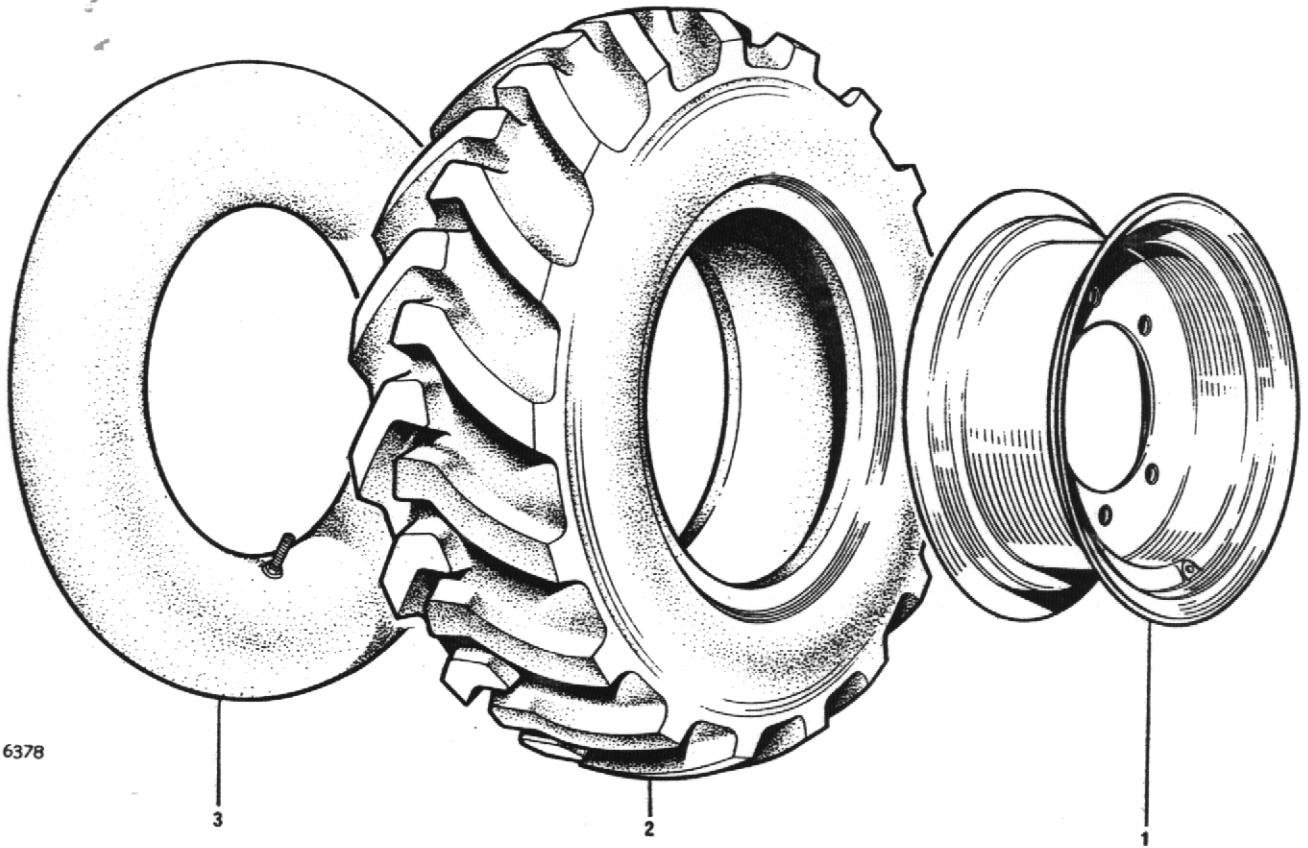

### WHEELS AND TYRES

Item No.	Part No.	Description	Qty.
1	24S04	R/H Wheel Assembly	2
	24S03	L/H Wheel Assembly	2
1	30192A01	Wheel rim 5.50 x 16	4
2	20S08	Tyre 7.50 x 16-6 ply	4
3	23S03	Tube 7.50 x 16	4

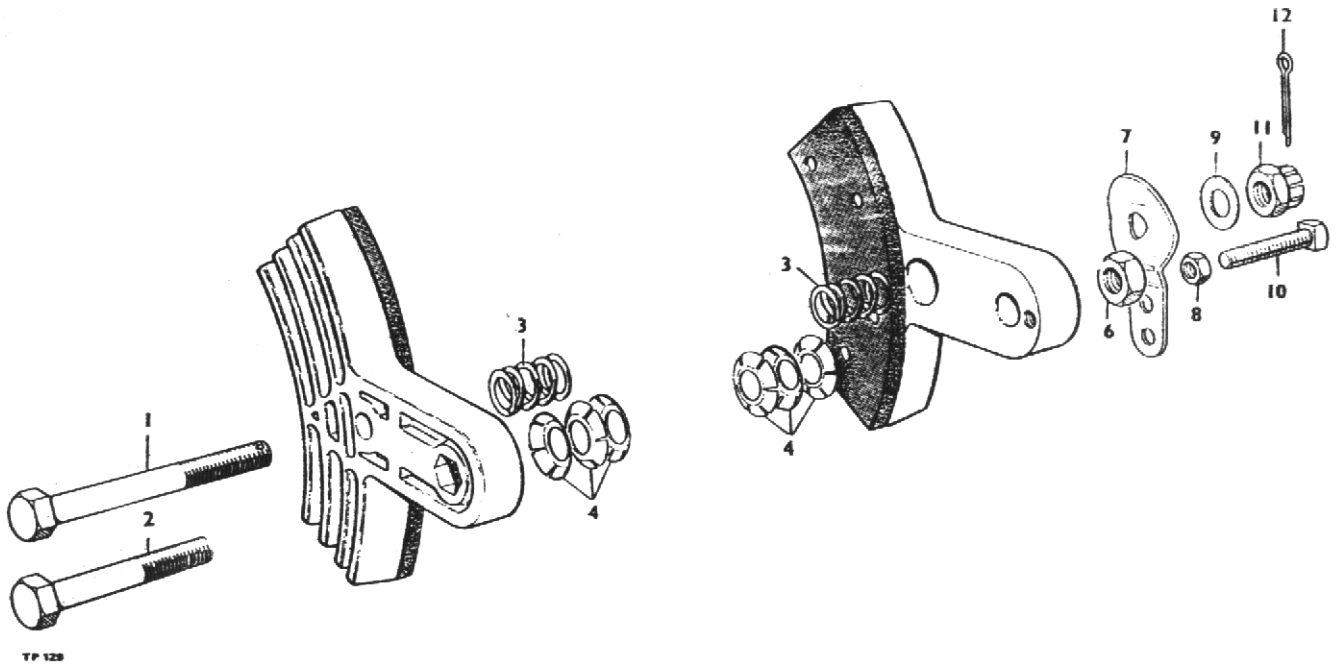

### CALIPER, parking brake

Item	Part no	Description	Qty
1A	10578A01	CALIPER, one pair, assembly	1
1	28S02T	SCREW	1
2	28S02P	SCREW	1
3	10578A0101	SPRING, centring	2
4	10578A0102	WASHER, tension	6
6	9S02	NUT	1
7	10578A0104	CAM	1
8	230S01	NUT, locking	1
9	10578A0105	WASHER	1
10	66S01H	SCREW, set	1
11	227S02	NUT, castle	1
12	44S01C	PIN, cotter	1
13	1072A4	PAD c/w rivets	2



## DRUM BRAKE ASSEMBLY

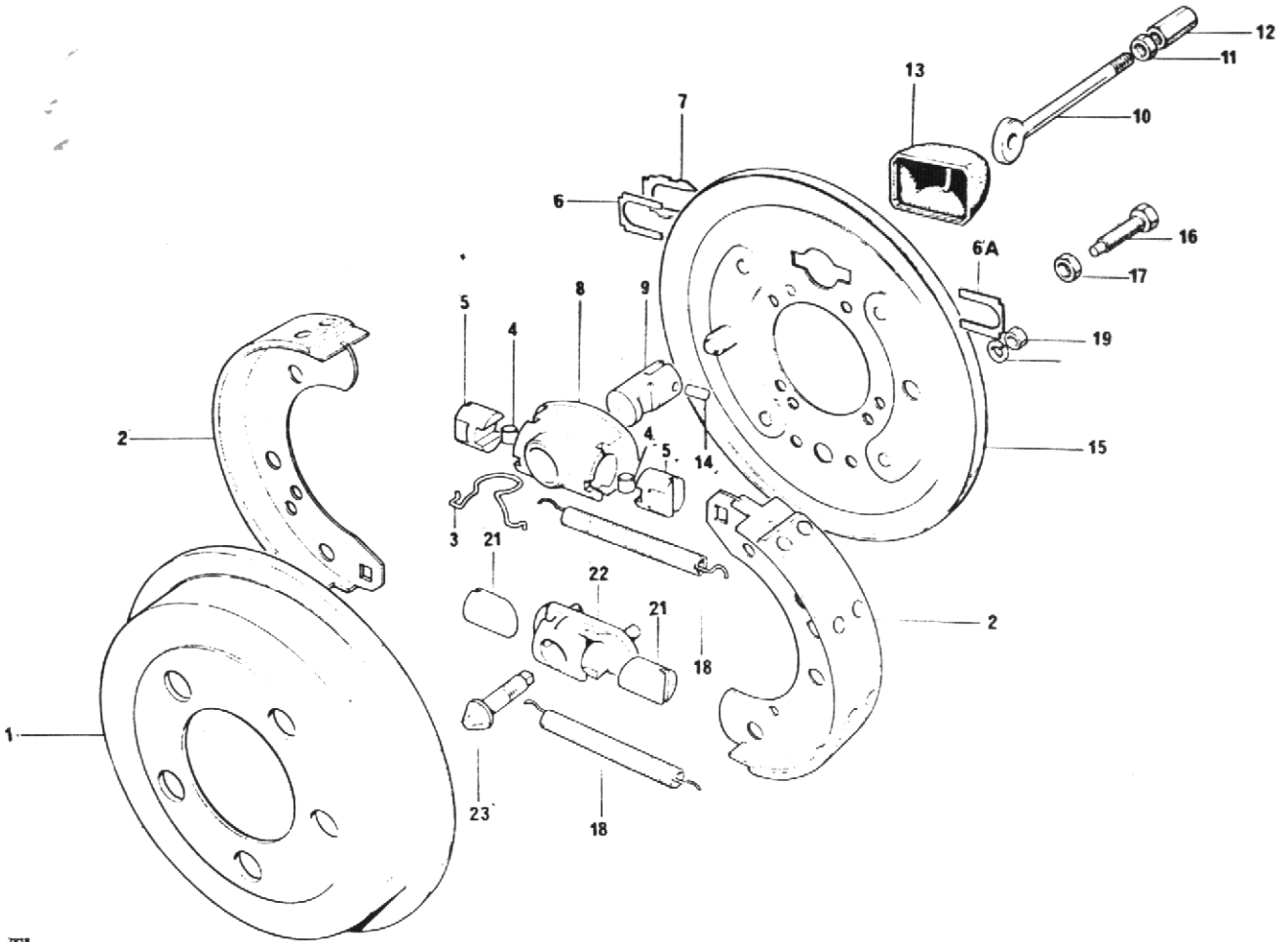

Item	Part No.	Description	Qty.
1	30088.A0128	Brake Drum	1
2	20298.A0101	Lined Shoe	2
3	20298.A0102	Spring	1
4	20298.A0103	Roller	2
5	20298.A0104	Tappet Expander	2
6	20298.A0105	Plate	1
6A	20298.A0106	Plate	1
7	20298.A0107	Locking Plate	1
8	20298.A0108	Expander Housing	1
9	20298.A0109	Plunger	1
10	20298.A0110	Drawlink	1
11	20298.A0111	Locknut	1
12	20298.A0112	Barrel Nut	1
13	20298.A0113	Dust Cover	1
14	20298.A0114	Pin	1
15	20298.A0115	Brake Back Plate	1
16	1S.02C	Setscrew 5/16" BSF	2
17	1S.03	Nut 5/16" BSF	2
18	20298.A0116	Spring	2
19	20298.A0117	Nut	2
20	20298.A0118	Washer	2
21	20298.A0119	Tappet Adjuster	2
22	20298.A0120	Adjuster Housing	1
23	20298.A0121	Wedge	2
24	20298.A0122	Service Kit (Adjuster) (N.I.)	A/R
25	20298.A0123	Adjuster Assy. (Compr: 19-25)	A/R
26	20298.A0124	Expr. Assy. (Compr: items 3,4,5,8,9,10,11,12,& 14)	A/R

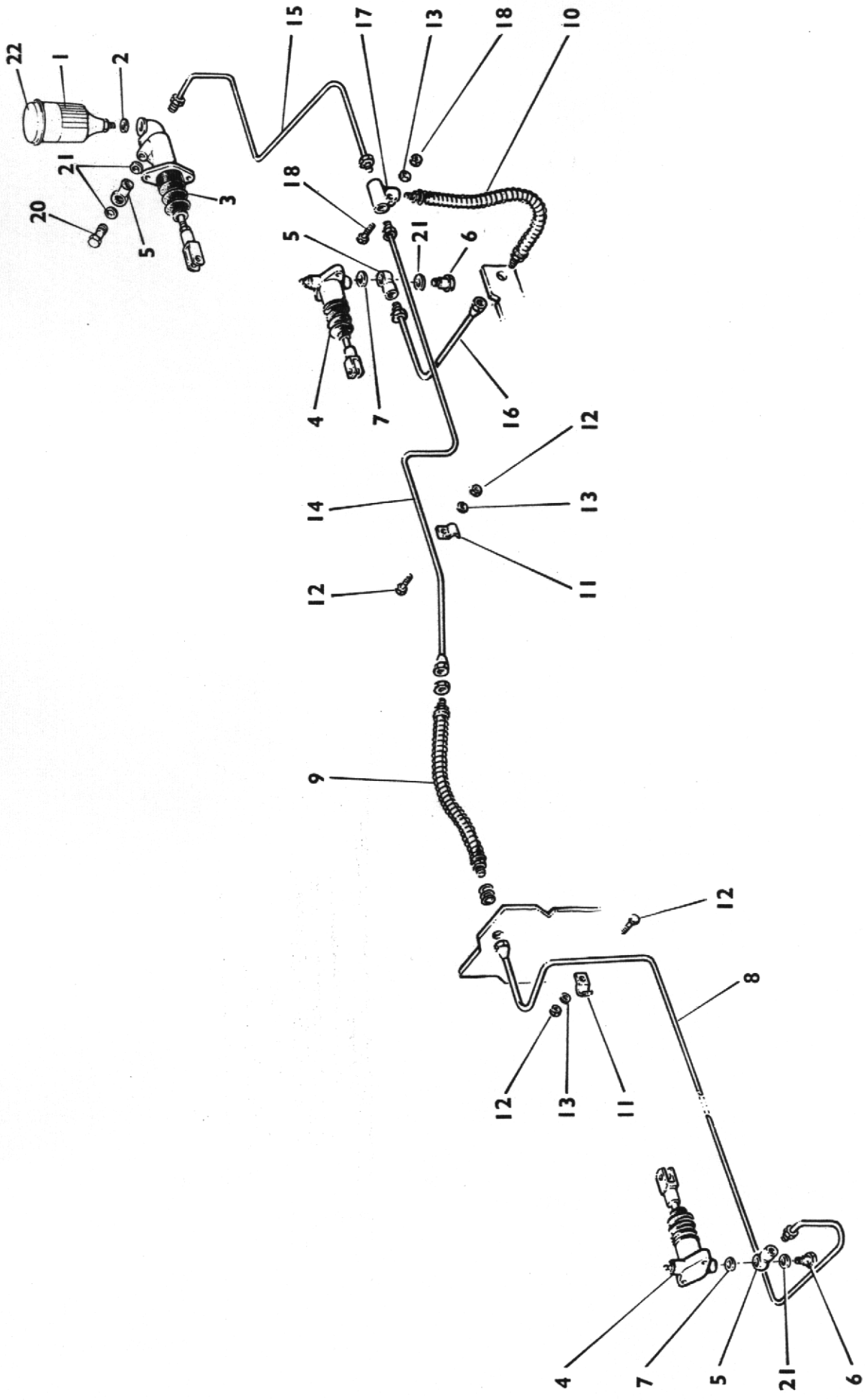

FWD. 

### BRAKE PIPES & CONNECTIONS

Item No.	Part No.	Description	Qty.
1	64046158	Header Tank . . . . .	1
2	4-35-378	Copper Washer 3/4" OD. x 7/16" ID. x 1/8" thick. . . . .	1
3	64066004	Master Cylinder (See Page 44) . . . . .	1
4	ASE 149	Slave Cylinder (See Page 45) . . . . .	2
5	64474287	Banjo . . . . .	2
6	376102 W	Banjo Bolt . . . . .	2
7	378703	Washer . . . . .	2
8	DM 79-5	Pipe . . . . .	1
9	64047903	Flex Pipe 11" . . . . .	1
10	64046115	Flex Pipe 9" . . . . .	1
11	4S 133	P Clip . . . . .	3
12		Bolt 1/4" BSF x 1" Long & Nut . . . . .	3
13		Shakeproof Washer 1/4" . . . . .	4
14	DM 79-4	Brake Pipe . . . . .	1
15	DM 88-7	Brake Pipe . . . . .	1
16	DM 79-6	Brake Pipe . . . . .	1
17	64474341	Tee Piece . . . . .	1
18		Bolt 1/4" BSF x 1 1/2" Long & Nut . . . . .	1
19	64474291	Banjo . . . . .	2
20	64473063	Banjo bolt . . . . .	2
21	378700	Washer . . . . .	4
22	64474602	Cap . . . . .	1

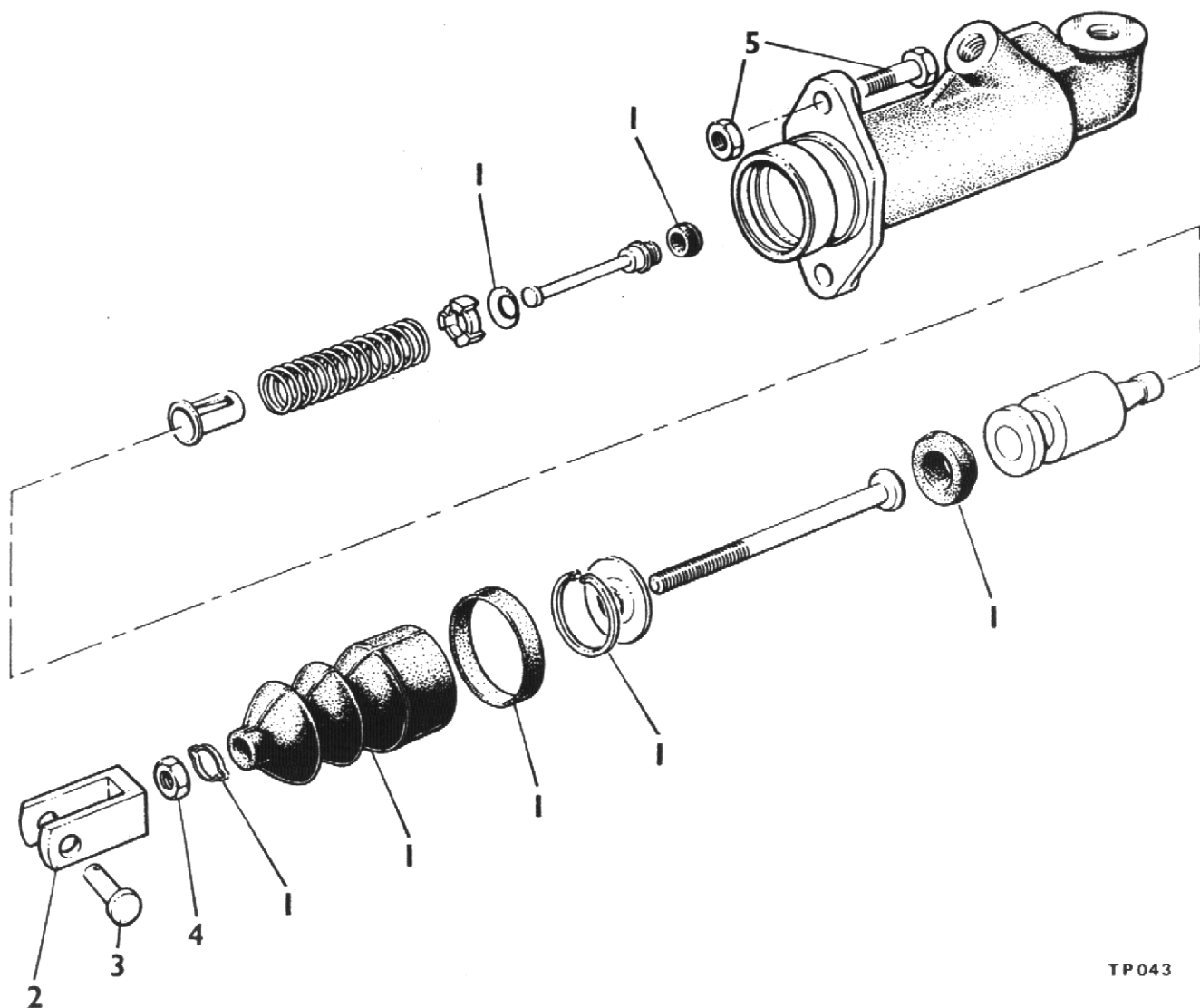

TP043

### BRAKE MASTER CYLINDER

Item No.	Part No.	Description	Qty.
	64066004	Master Cylinder Complete . . . . .	1
1	SP.2636	Service Kit . . . . .	A/R
2	64671286	Clevis . . . . .	1
3	C174Y	Clevis Pin . . . . .	1
4	64100052	Locknut . . . . .	1
5		Bolt 3/8" BSF x 1 1/2" Long & Nut . . . . .	2

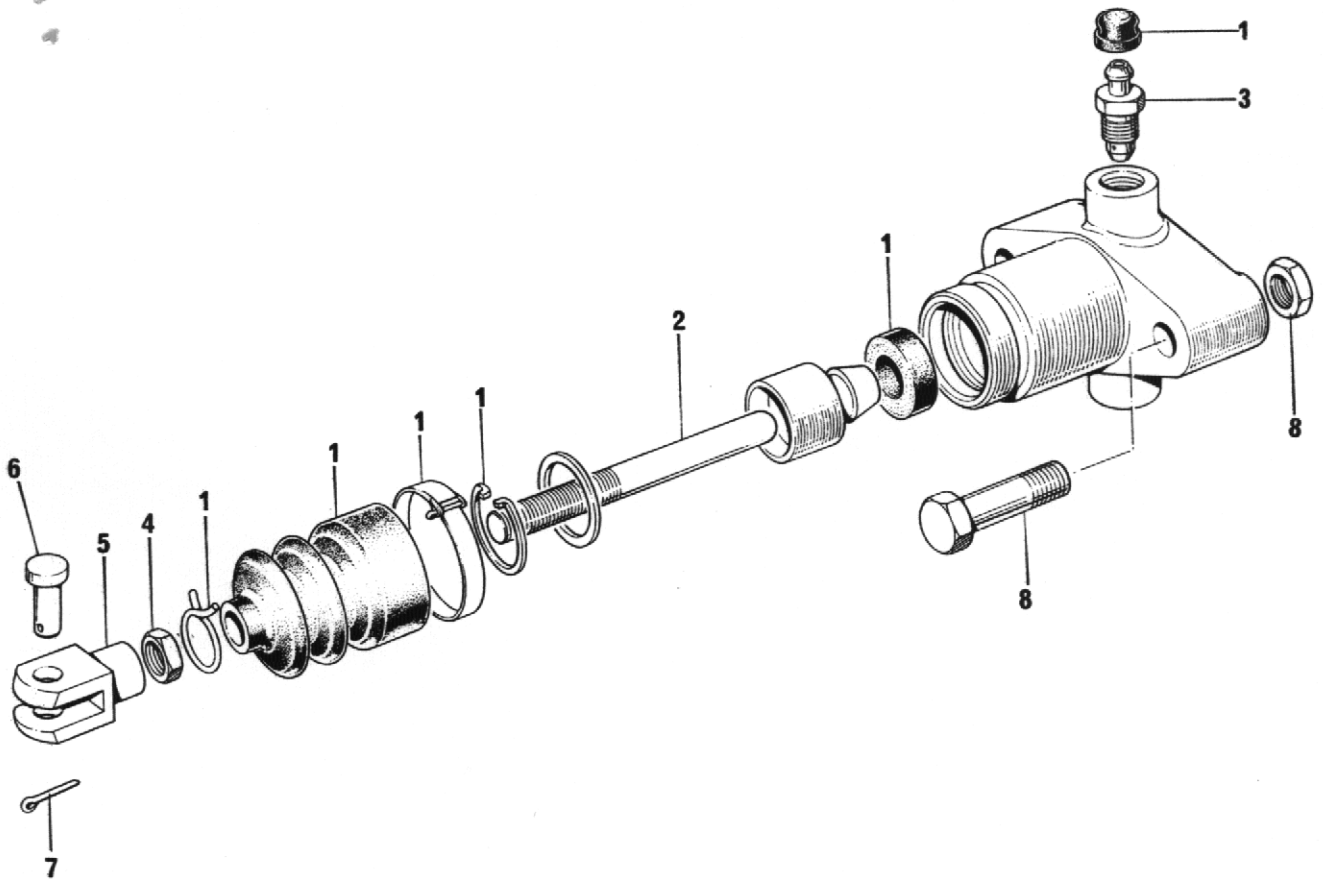

10043

### BRAKE SLAVE CYLINDER ASSEMBLY

Item No.	Part No.	Description	No. Off
	ASE 149	Slave Cylinder Complete	1
1	SP 2694	Repair Kit	1
2	ASE 117	Push Rod	1
3	64470444	Bleed Nipple	1
4		Nut $\frac{3}{8}$ " BSF	1
5	C 174A	Clevis	1
6	C 174X	Clevis Pin	1
7		Split Pin $\frac{3}{32}$ " Dia.	1
8		Bolt $\frac{5}{16}$ " BSF x $1\frac{3}{4}$ " Long and Nut	2

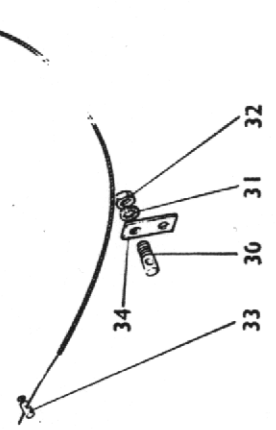
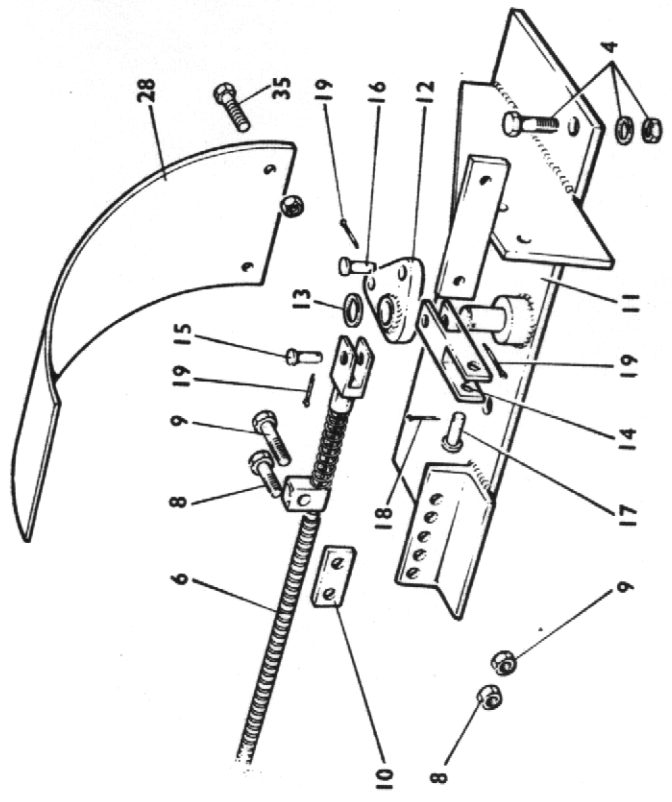
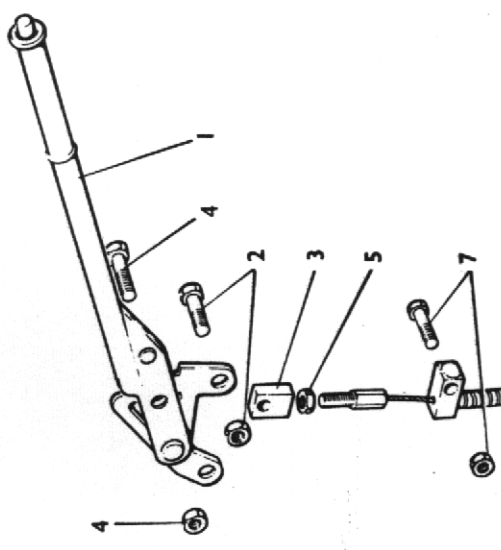
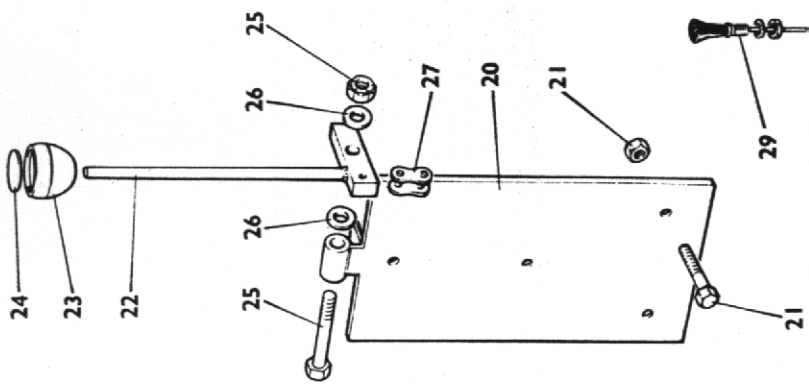

**HANDBRAKE VALVE CONTROL LEVER &  
ENGINE STOP CONTROL**

<b>Item No.</b>	<b>Part No.</b>	<b>Description</b>	<b>Qty</b>
1	303	Handbrake lever .....	1
2		Bolt M10 x 25mm long & locknut .....	2
3	L309	Block .....	1
4		Bolt M10 x 40mm long & locknut .....	4
5		Nut 3/8" BSF .....	1
6	4-35-111	Handbrake cable .....	1
7		Bolt M8 x 35mm long & locknut .....	1
8		Bolt M8 x 25mm long & locknut .....	1
9		Bolt M8 x 45mm long & locknut .....	1
10	4-35-349	Disc Brake adjusting Plate .....	1
11	CSE 166	Transmission Brake Mounting Bracket .....	1
12	4-35-256	Bell crank .....	1
13		Flat washer 1/2" dia .....	1
14	4-35-253	Double clevis .....	1
15	C174X	Clevis Pin .....	1
16	C174Y	Clevis Pin .....	1
17	4-35-264	Clevis Pin .....	1
18		Split Pin 1/16" dia .....	1
19		Split Pin 3/32" dia .....	3
20	F4-45-173	Hydraulic Valve Mounting Bracket .....	1
21		Bolt M10 x 30mm long & locknut .....	2
22	F4-45-185	Hydraulic Valve Lever .....	1
23	10211 .A01	Knob .....	1
24	10284 .A01	Label .....	1
25		Bolt 3/8" BSF x 2 1/4" long & 2 locknuts .....	1
26		Flat washer 3/8" dia .....	2
27	4-60-178	Connecting Link .....	1
28	CSE 165	Handbrake Disc Guard .....	1
29	4-60-239	Engine stop control cable assembly .....	1
30	4-60-242	Clamp Screw .....	1
31		Springwasher 3/8" dia .....	1
32		Nut 3/8" UNF .....	1
33	4-35-196	Solderless nipple .....	1
34	CSE 145	Stop Control cable bracket .....	1
35		Bolt M6 x 20mm long & locknut .....	2

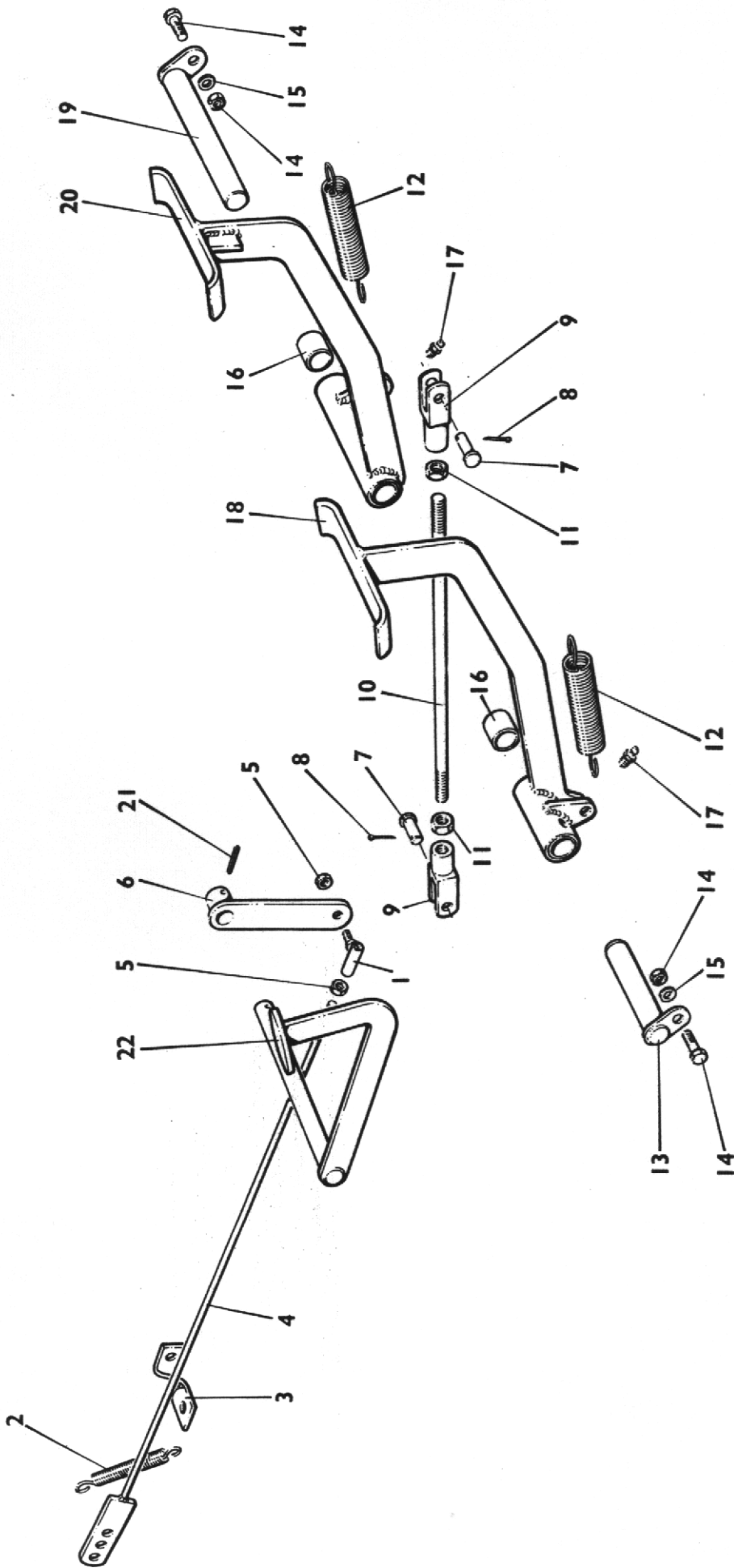



## PEDALS AND CONTROLS

Item No.	Part No.	Description	Qty
1	C160 B	Accelerator Rod Ball End . . . . .	1
2	C173 D	Spring . . . . .	1
3	C163	Spring Attachment Bracket . . . . .	1
4	10322.A01	Accelerator Rod . . . . .	1
5	2802	Nut 1/4 in. BSF . . . . .	2
6	C129	Accelerator Lever . . . . .	1
7	C174 X	Pin . . . . .	2
8		Split Pin 3/32 in. x 1in. . . . .	2
9	C174 A	Clevis . . . . .	2
10	T21A	Clutch Rod 3/8 in. BSF x 12 1/2 in. Long . . . . .	1
11		Nut 3/8 in. BSF . . . . .	2
12	C173 B	Spring . . . . .	2
13	CSE 114	Brake Pedal Pivot Pin . . . . .	1
14		Bolt M8 x 25mm Long & Nuts (Pedal Pins) . . . . .	2
15		Plain Washer M8 . . . . .	2
16	WB 1010	Bush . . . . .	4
17	T-ST	Grease Nipple . . . . .	2
18	BSE 166	Footbrake Pedal . . . . .	1
19	CSE 113	Clutch Pedal Pivot Pin . . . . .	1
20	BSE 172	Clutch Pedal . . . . .	1
21	C129A	Tension Pin . . . . .	1
22	CSE 111	Accelerator Pedal . . . . .	1

## DRUM BRAKE OPERATING LINKAGE

(Not Illustrated)

Item No.	Part No.	Description	Qty.
1	C272	Compensator Lever . . . . .	1
2	5ST 100	Grease Nipple . . . . .	1
3	C271	Compensator Link Assembly . . . . .	1
4	C189A	Compensator Link . . . . .	1
5	10S.4	Plain Washer 1/2" Dia. . . . .	2
6	44S.3C	Split Pin 1/8" Dia. x 1" Long . . . . .	2
7	C171-B	Brake Rod 1/4" Dia. x 29 1/2" Long . . . . .	1
8	C174C	Clevis Fork End . . . . .	2
9	9S.1	Nut 1/4" UNF . . . . .	4
10	10650A14	Clevis Pin 5/16" Dia. . . . .	2
11	10S.2	Plain Washer 5/16" Dia. . . . .	2
12	44S.2B	Split Pin 3/32" Dia. x 3/4" Long . . . . .	2
13	C171A	Brake Rod 1/4" Dia. x 11 1/2" Long . . . . .	1

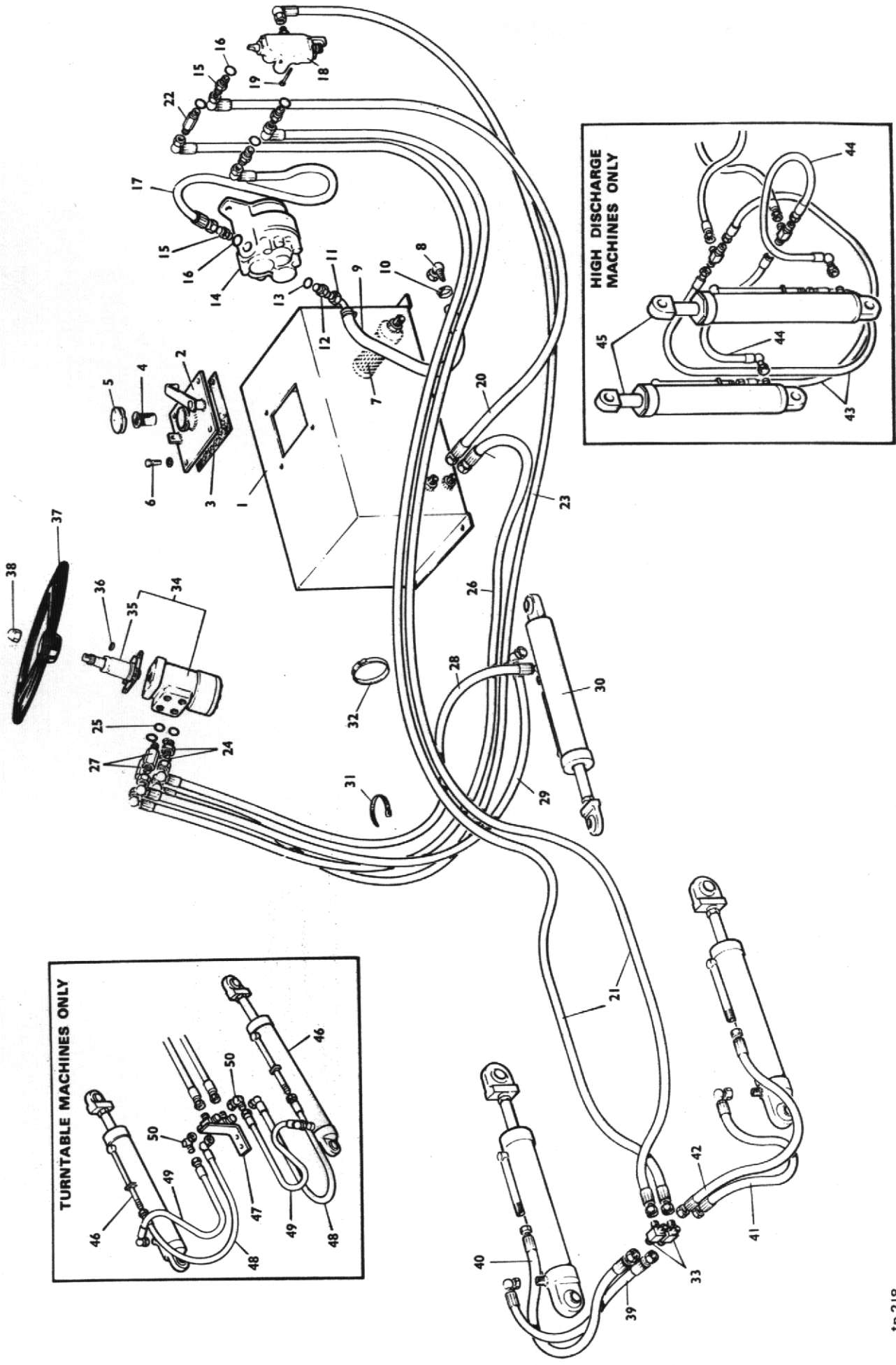

## HYDRAULIC PIPES & FITTINGS

Item No.	Part No.	Description	Qty.
1	CSE. 123	Hydraulic Tank	1
2	4-35-187	Cover Plate Assembly	1
3	T18B	Gasket	1
4	P1145	Strainer	1
5	P2578-2	Cap	1
6		Bolt M8 x 20mm Long	4
7	UC1457	Filter	1
8	BSE 109	90° Hose Fitting ¾ in. BSP	1
9	CSE 203	Hose ¾ in. Cotton Braid x 14 in. Long.	1
10	T63 M	Hose Clip	2
11	ASE 136	90° Hose Fitting 5/8 in. BSP	1
12	ASE 129	Adaptor 5/8 in. BSP x 1 1/16 in. SAE	1
13	ASE 138	'O' Ring 1 1/16 in.	1
14	200-100-RAB	Pump	1
15	CSE 186	Adaptor 7/8 in. UNF x 3/8 in. BSP (Short)	5
16	S9698	'O' Ring 7/8 in.	6
17	3SH 61	Hose 3/8 in. x 61 in. 90° - 90°	1
18	300-024-GAE	Hydraulic Control Valve	1
19		Bolt 5/16 in. UNF x 2½ in. Long.	2
20	4-60-133	Hose 3/8 in. x 48 in. ST - 90°	1
21	4-35-294	Hose 3/8 in. x 112 in. ST - 90°	2
22	4-60-158	Adaptor 3/8 in. BSP x 7/8 in. JIC (Long)	1
23	4SHL 86	Hose 3/8 in. x 98 in. 90° - 90°	1
24	4-35-40K	Adaptor 3/8 in. BSP x 3/4 in. UNF (Short)	2
25	2ST 72J	'O' Ring	4
26	4-35-246	Hose 3/8 in. x 67 in. ST - 90°	1
27	4-60-115	Adaptor 3/8 in. BSP x 3/4 in. UNF	2
28	CSE 138	Hose 3/8 in. x 62 in. 90° - 90°	1
29	CSE 137	Hose 3/8 in. x 68 in. 90° - 90°	1
30	TD 3894	Hydraulic Ram	3
31	177	Cable Tie	1
32		Jubilee Clip 32/48mm	1
33	2ST 72M	Tee	2
34	CSE 178	Steering Valve Complete	1
35	099-530063	Steering Column	1
36	CSE 182	Spacer	2
37	40064.A01	Steering Wheel	1
	10314.A01	Steering Wheel Cap	1
38	C318	Domed Nut	1
39	3SHD 65	Hose 3/8 in. x 31½ in. ST - ST	1
40	4-35-365	Hose 3/8 in. x 20 in. ST - 90°	1
41	2ST 72D	Hose 3/8 in. x 34½ in. ST - 90°	1
42	4-35-40E	Hose 3/8 in. x 36 in. 90° - 90°	1
43	4-35-108J	Hose 3/8 in. x 36 in. ST - ST (High Discharge)	2
44	4-35-365	Hose 3/8 in. x 20 in. ST - 90° (High Discharge)	2
45	BE - 3	Hydraulic Ram (High Discharge)	2
46	TD 3894	Hydraulic Ram (Turntable)	2
47	ASE 148	Tee Assembly (Turntable)	1
48	4-35-365	Hose 3/8 in. x 20 in. ST - 90° (Turntable)	2
49	2ST 72C	Hose 3/8 in. x 13¼ in. ST - 90° (Turntable)	2
50	2ST 72N	Elbow 3/8 in. BSP 90° (Swivel) (Turntable)	2

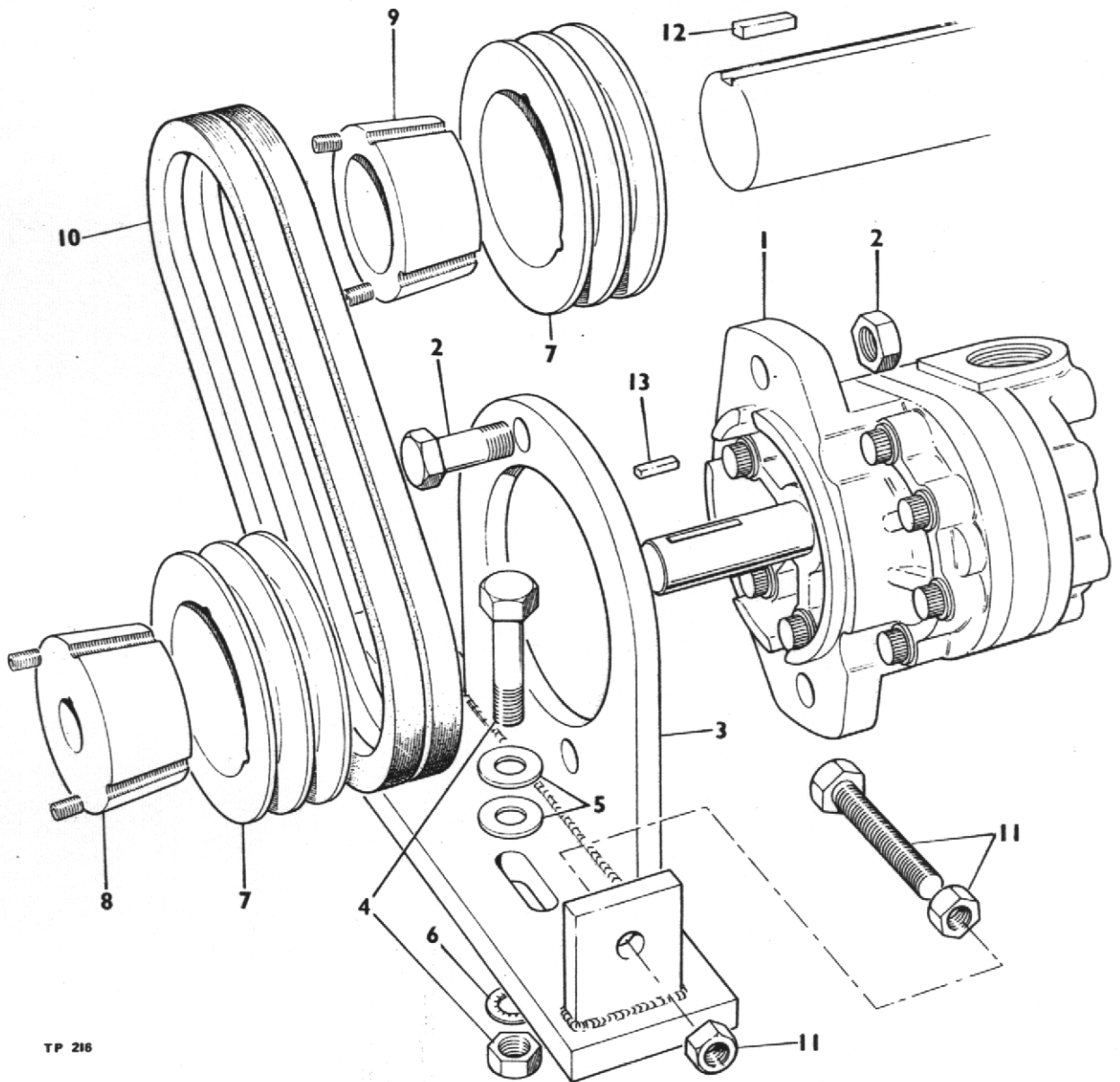

TP 216

### HYDRAULIC PUMP & DRIVE

Item No.	Part No.	Description	Qty
1	200-100-RAB	Pump . . . . .	1
2		Bolt 3/8 in. BSF x 1 1/4 in. Long and Nut . . . . .	2
3	ASE 204	Pump Mounting Bracket . . . . .	1
4		Bolt 3/8 in. BSF x 1 1/2 in. Long and Nut . . . . .	2
5		Flat Washer 3/8 in. Dia. . . . .	4
6		Shakeproof Washer . . . . .	2
7	2ST 122	Pulley . . . . .	2
8	ASE 120	Taperlock Bush . . . . .	1
9	2ST 123	Taperlock Bush . . . . .	1
10	3SHD 73	Wedge Belt . . . . .	2
11		Setscrew 3/8 in. BSF x 3 in. Long and 2 Nuts . . . . .	1
12	ASE 159	Key (Engine) . . . . .	1
13	15511-44	Key (Pump) . . . . .	1

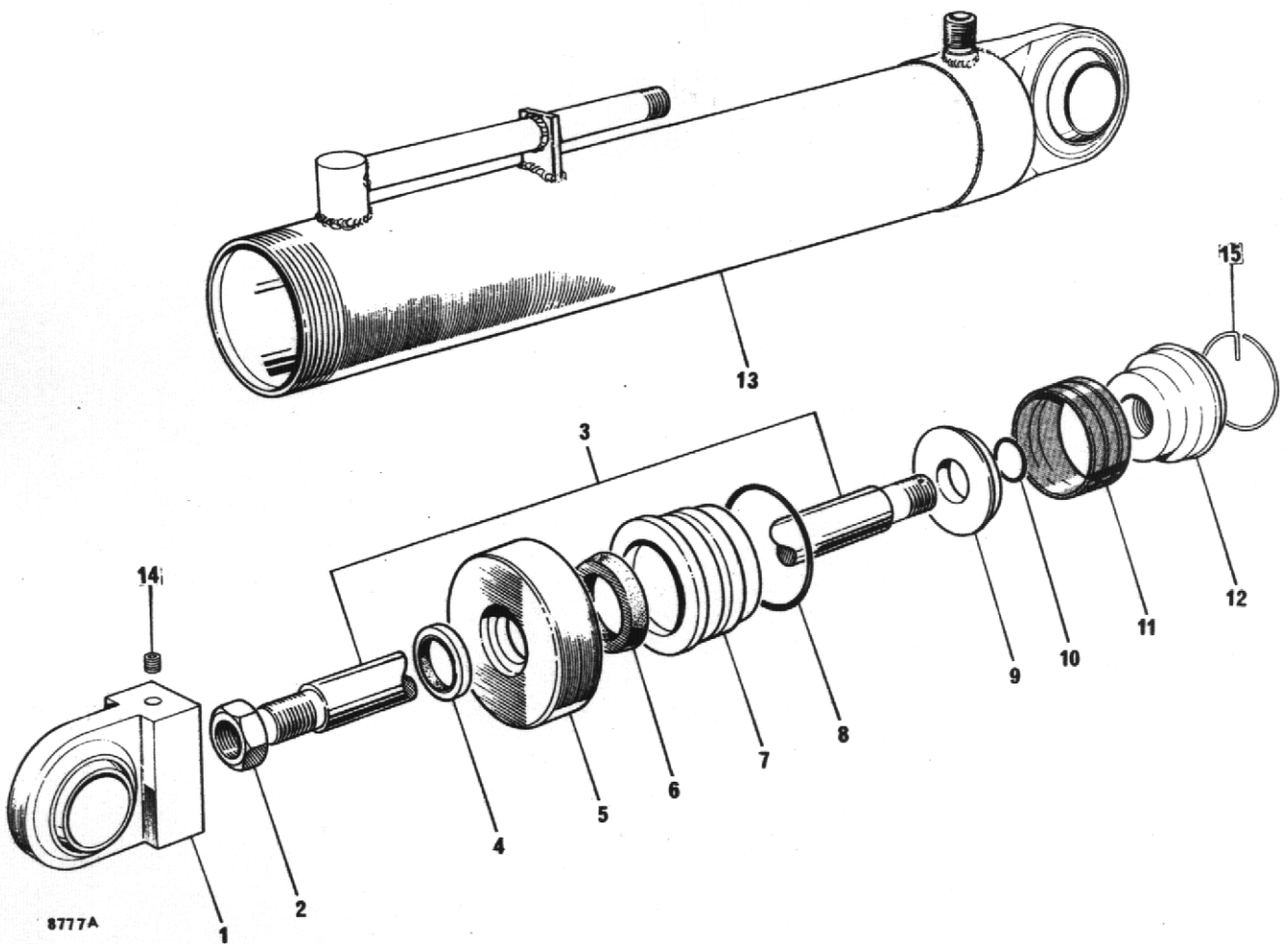

### HYDRAULIC RAM

Item No.	Part No.	Description	Qty.
	TD3894	Ram Complete (3 Per Machine — 1 on high discharge machine)	
1	K1/11	Piston Rod Fitting . . . . .	1
2	K1/19	Locknut . . . . .	1
3	K1/2	Piston Rod . . . . .	1
4	K1/18	Wiper . . . . .	1
5	K1/4	Tube Cap . . . . .	1
6	K1/17	Sleeve Seal . . . . .	1
7	K1/5	Sleeve . . . . .	1
8	K1/16	Sleeve 'O' Ring . . . . .	1
9	K1/15	Backing Washer . . . . .	1
10	K1/13	Piston 'O' Ring . . . . .	1
11	K1/12	Piston Seal . . . . .	1
12	K1/14	Piston Head . . . . .	1
13	K1/20	Cylinder, Bosses & End Cap . . . . .	1
14	K1/21	Grub Screw . . . . .	1
15	K1/22	Spring Ring . . . . .	1
	CSE 189	Seal Kit comp. items 4,6,8,10 and 11 . . . . .	A/R

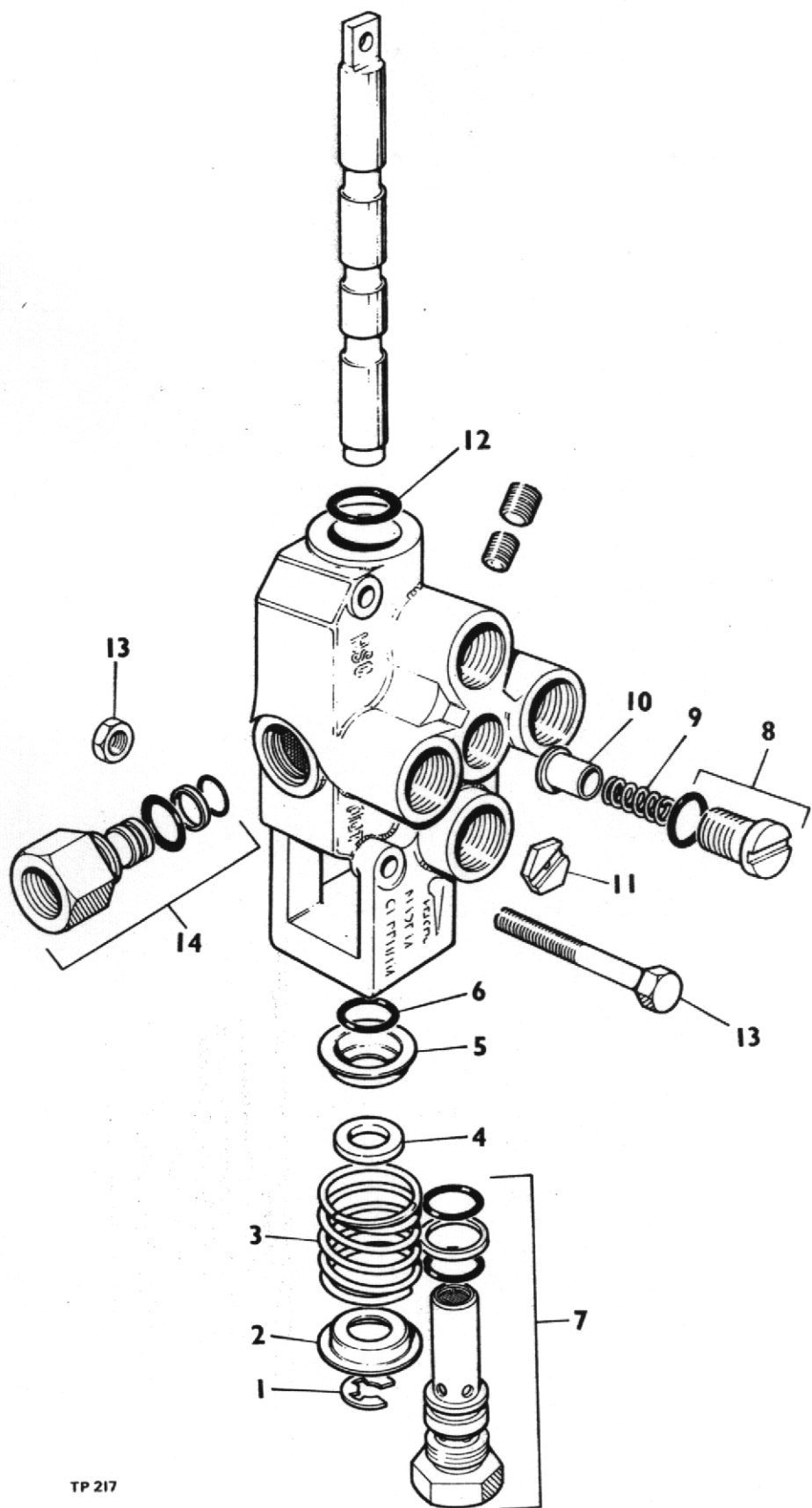

TP 217

## HYDRAULIC CONTROL VALVE

Item No.	Part No.	Description	Qty.
	300-024-GAE	Control Valve Assembly (1 Per M/c)	
1	16124-50	Clip Ring (½ in. Shaft)	1
2	15546-6	Shallow Washer	1
3	30501-39	Spool Spring	1
4	16048-31	Washer Spacer	1
5	30501-10	Deep Washer	1
6	100-146-012	'O' Ring 3/32 in. x 5/8 in. I/D	1
7	300-055-C9A	Relief Valve Assembly 1000 p.s.i.	1
8	30501-17	Lift Check Plug Assembly	1
9	30501-13	Lift Check Spring	1
10	30501-12	Lift Check Plunger	1
11	16097-451	Orifice Plate	1
12	100-147-063	'O' Ring	1
13		Bolt 5/16 in. UNF x 2½ in. Long & Nut	2
14	30501-15	Pressure Beyond Plug Assembly	1

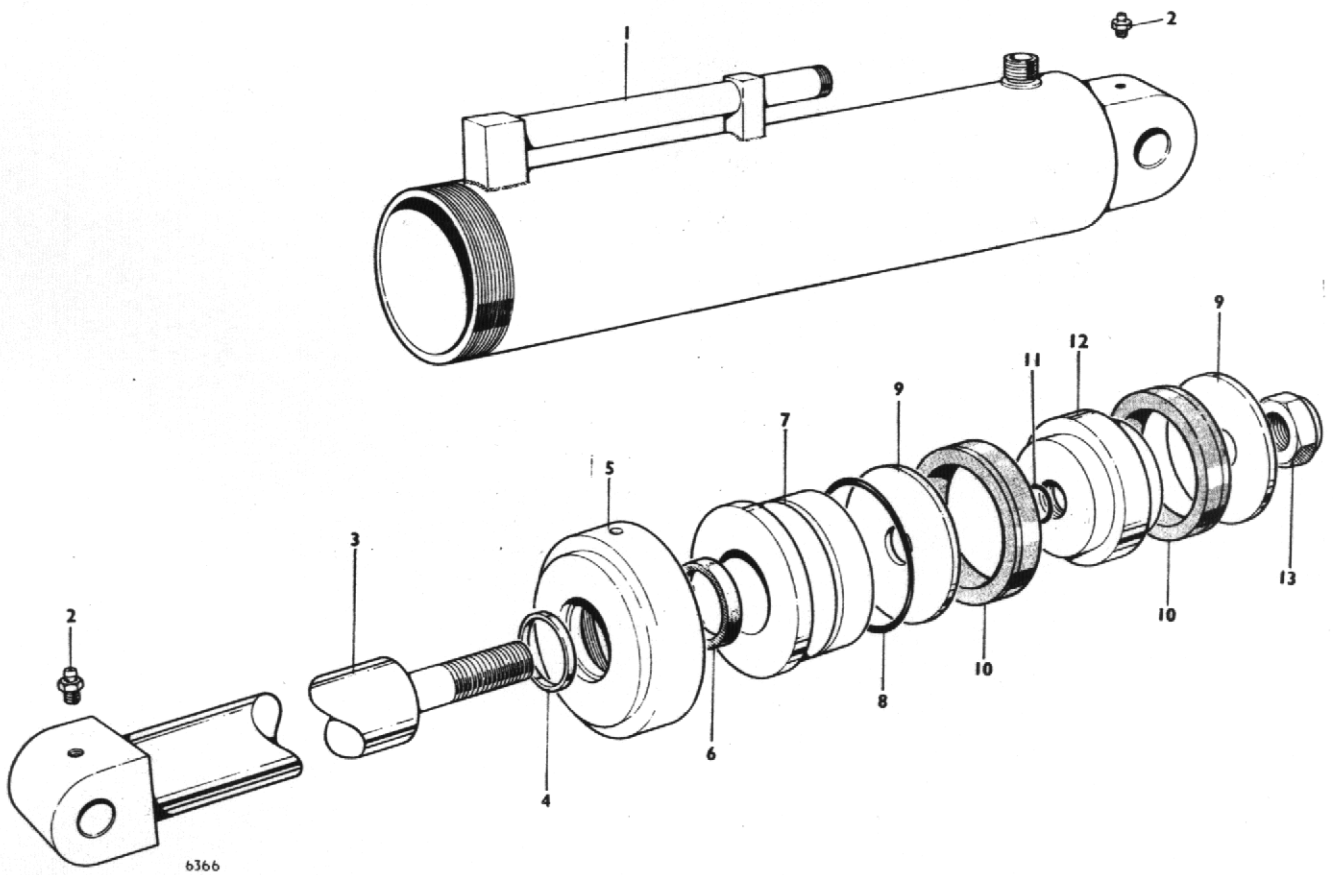

### HIGH DISCHARGE HYDRAULIC RAM

Item No.	Part No.	Description	Qty.
	BE-3	Ram Assembly Complete (Two per high discharge m/c's only)	
1	BE3-21	Ram Body . . . . .	1
2	BE3-20	Grease Nipple . . . . .	2
3	BE3-22	Piston Rod Assembly . . . . .	1
4	BE3-15	Wiper . . . . .	1
5	BE3-6	Tube Cap . . . . .	1
6	BE3-16	Sleeve Seal . . . . .	1
7	BE3-7	Sleeve . . . . .	1
8	BE3-13	Sleeve 'O' Ring . . . . .	1
9	BE3-10	Backing Washer . . . . .	2
10	BE3-14	Piston Seal . . . . .	2
11	BE3-12	Piston 'O' Ring . . . . .	1
12	BE3-9	Piston Head . . . . .	1
13	BE3-11	Lock Nut . . . . .	1
	CSE 190	Seal Kit comp. items 4,6,8,10 and 11.....	A/R



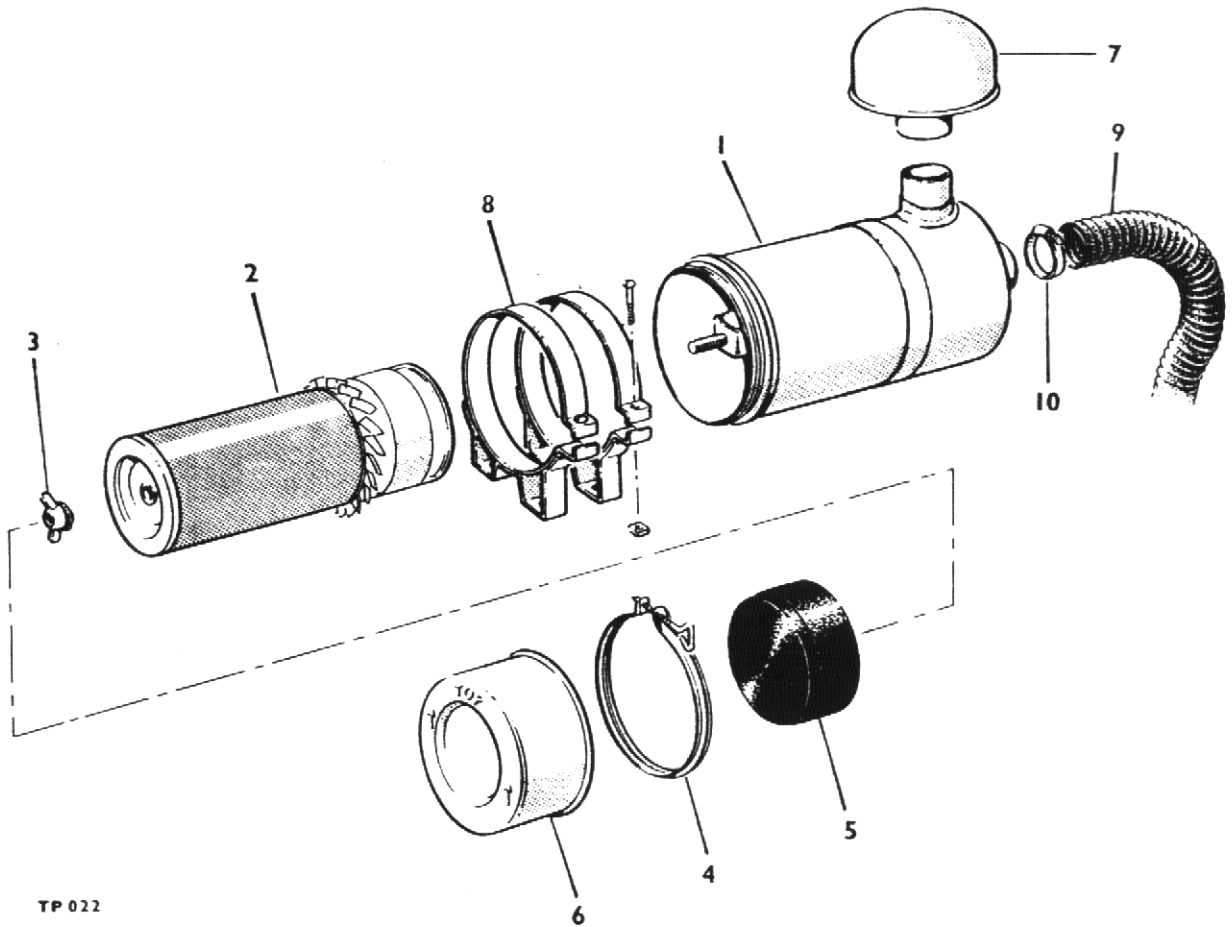

TP 022

### AIR CLEANER

Item No.	Part No.	Description	Qty.
1	10532A02	Air Cleaner Assembly	1
2	10532A0101	Element	1
3	V600487	Nut & Gasket Kit	1
4	220229002	Clamp Body	1
5	220229003	Skirt, baffle	1
6	220229004	Cup	1
7	10534A02	Stack Cap	1
8	10533A02	Bracket	2
9		Hose Flexible 2" Bore x 19" Long	1
10	97S12	Hose Clip	2

## DECIMAL, FRACTIONAL AND METRIC EQUIVALENTS

Inches		Milli- metres	Inches		Milli- metres
Fractions	Decimals		Fractions	Decimals	
1/64	0.015625	0.397	33/64	0.515625	13.097
1/32	0.03125	0.794	17/32	0.53125	13.494
3/64	0.046875	1.191	35/64	0.546875	13.891
1/16	0.0625	1.588	9/16	0.5625	14.288
5/64	0.078125	1.984	37/64	0.578125	14.684
3/32	0.09375	2.381	19/32	0.59375	15.081
7/64	0.109375	2.778	39/64	0.609375	15.478
1/8	0.125	3.175	5/8	0.625	15.875
9/64	0.140625	3.572	41/64	0.640625	16.272
5/32	0.15625	3.969	21/32	0.65625	16.669
11/64	0.171875	4.366	43/64	0.671875	17.066
3/16	0.1875	4.763	11/16	0.6875	17.463
13/64	0.203125	5.159	45/64	0.703125	17.859
7/32	0.21875	5.556	23/32	0.71875	18.256
15/64	0.234375	5.953	47/64	0.734375	18.653
1/4	0.250	6.350	3/4	0.750	19.050
17/64	0.265625	6.747	49/64	0.765625	19.447
9/32	0.28125	7.144	25/32	0.78125	19.844
19/64	0.296875	7.541	51/64	0.796875	20.241
5/16	0.3125	7.938	13/16	0.8125	20.638
21/64	0.328125	8.334	53/64	0.828125	21.034
11/32	0.34375	8.731	27/32	0.84375	21.431
23/64	0.359375	9.128	55/64	0.859375	21.828
3/8	0.375	9.525	7/8	0.875	22.225
25/64	0.390625	9.922	57/64	0.890625	22.622
13/32	0.40625	10.319	29/32	0.90625	23.019
27/64	0.421875	10.716	59/64	0.921875	23.416
7/16	0.4375	11.113	15/16	0.9375	23.813
29/64	0.453125	11.509	61/64	0.953125	24.209
15/32	0.46875	11.906	31/32	0.96875	24.606
31/64	0.484375	12.303	63/64	0.984375	25.003
1/2	0.500	12.700	1	1.000	25.400

## INCHES INTO MILLIMETRES

Inches	0	1	2	3	4	5	6	7	8	9
0	0	25.40	50.80	76.20	101.60	127.00	152.40	177.80	203.20	228.60
10	254.00	279.40	304.80	330.20	355.60	381.00	406.40	431.80	457.20	482.60
20	508.00	533.40	558.80	584.20	609.60	635.00	660.40	685.80	711.20	736.60
30	762.00	787.40	812.80	838.20	863.60	889.00	914.40	939.80	965.20	990.60
40	1016.00	1041.40	1066.80	1092.20	1117.60	1143.00	1168.40	1193.80	1219.20	1244.60
50	1270.00	1295.40	1320.80	1346.20	1371.60	1397.00	1422.40	1447.80	1473.20	1498.60
60	1524.00	1549.40	1574.80	1600.20	1625.60	1651.00	1676.40	1701.80	1727.20	1752.60
70	1778.00	1803.40	1828.80	1854.20	1879.60	1905.00	1930.40	1955.80	1981.20	2006.60
80	2032.00	2057.40	2082.80	2108.20	2133.60	2159.00	2184.40	2209.80	2235.20	2260.60
90	2286.00	2311.40	2336.80	2362.20	2387.60	2413.00	2438.40	2463.80	2489.20	2514.61

Use in conjunction with above table.

Example: Find equivalent mm. for 84 5/8".

$$84'' = 2133.60 \text{ mm.}$$

$$5/8'' = 15.875 \text{ mm.}$$

$$84 \text{ } 5/8'' = 2149.475 \text{ mm.}$$

# CALIFORNIA

## Proposition 65 Warning

**Diesel engine exhaust and some of its constituents are known to the State of California to cause cancer, birth defects, and other reproductive harm**